

twist

DESIGN: LORENZO MARCOLIN

NEWTOM

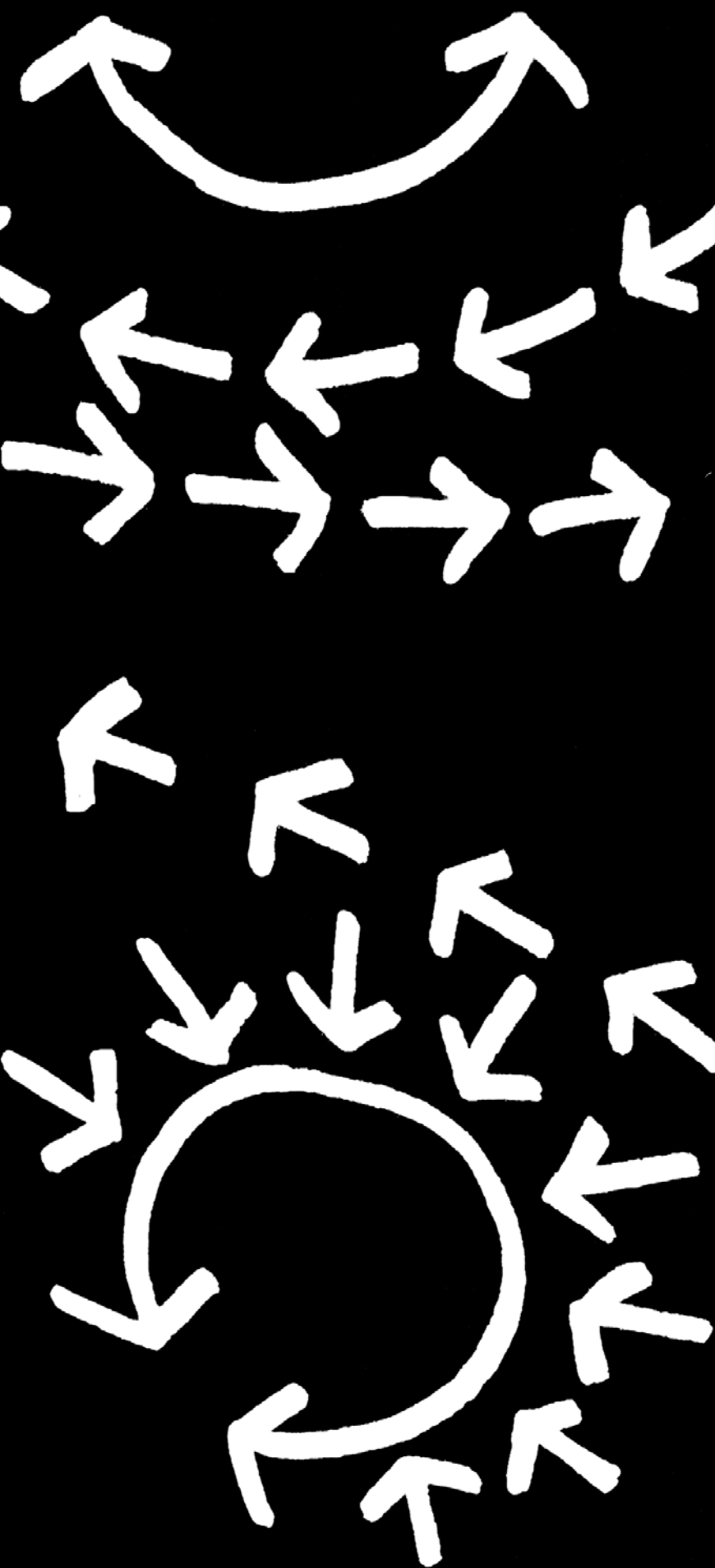



Twist è un'idea di ufficio "facile" che considera il lavoro come il risultato di un'esperienza collettiva alla quale appartiene anche il tempo della ricreazione.

Un "fare" condiviso a cui ogni singolo operatore interviene con capacità, competenze e sensibilità proprie.

Il suo spazio è un connettivo esteso che facilita le relazioni e gli scambi sinergici, una dimensione fluida e dinamica in cui gli aspetti organizzativi e funzionali "del fare" si integrano con quelli emozionali "dell'essere".

La sua architettura è costituita da elementi di arredo dedicati all'accoglienza al lavoro singolo o di relazione, all'archiviazione ed alla ricreazione.

Contraddistinti da forme arrotondate e colorate essi intervengono nell'ambiente ufficio, realizzano "luoghi di partecipazione" sensibili, inusuali e stimolanti.

Twist is an "easy" office idea which considers work as the result of a collective experience also in moments dedicated to recreation.

A shared way of "doing" with each single operator conveying their own capacity, competence and sensitivity.

Its space is an extensive connectivity that facilitates synergic relations and exchange, a fluid and dynamic dimension in which the organizational and practical aspects of "doing" integrate with the emotional states of "being".

Its architecture consists of furnishing elements dedicated to reception at work for the single person or groups, archiving and recreation.

Distinguished by rounded and coloured shapes they go into the office environment, creating sensitive, unusual and stimulating "places of participation".

TWIST
DESIGN: LORENZO MARCOLIN

Twist est une idée de bureau "facile", qui considère le travail comme le résultat d'une expérience collective, y compris le temps de la récréation.

Un dynamisme partagé où chaque opérateur intervient avec les capacités, les compétences et la sensibilité qui lui sont propres.

Son espace est un vaste élément de contact, qui facilite les relations et les échanges synergiques, une dimension fluide et dynamique où les aspects de l'organisation et les côtés fonctionnels du dynamisme s'intègrent avec les aspects émotionnels de l'être.

Son architecture comprend des structures d'ameublement destinées à l'accueil, au travail individuel ou convivial, au classement et à la récréation.

Caractérisés par des formes rondes et colorées, ces éléments interviennent dans l'espace bureau pour réaliser des lieux de participation sensibles, inusuels et stimulants.

Twist stellt die Auffassung eines „unkomplizierten“ Büros dar, welche die Arbeit als das Ergebnis einer kollektiven Erfahrung betrachtet, zu der auch die Pausenzeit gehört.

Ein aktives Miteinander, an dem jeder Einzelne mit seinen Fähigkeiten, Kompetenzen und seinen Neigungen teilnimmt.

Sein Raum ist ein erweitertes Bindeglied, dass die Beziehungen und den synergetischen Austausch erleichtert, eine fließende und dynamische Dimension, in der sich die organisatorischen und funktionellen Aspekte „des Machens“ mit den emotionellen „des Seins“ integrieren.

Seine Architektur besteht aus Einrichtungsgegenständen, die der Aufnahme der einzelnen Arbeit oder der Teamarbeit, der Archivierung und den Pausen gewidmet sind.

Twist zeichnet sich durch abgerundete und bunte Formen aus, die in das Büroumfeld eingreifen und aufnahmebereite, unübliche und anregende „Orte der Teilnahme“ schaffen.

NEWTOM

L'accoglienza twist è costituita da postazioni organizzate secondo due tipologie d'uso: tipo centrico, definite da uno o più elementi circolari "spicchi operativi" o lineare, ottenute dall'unione di sezioni elementari di operatività; esse sono costituite da pannelli ottenuti dalla sovrapposizione di doghe dritte o sagomate cromaticamente differenziabili ai quali sono vincolati piani di servizio in vetro e di lavoro.

Sono "isole o fronti" di relazione che, per forma, caratteristiche cromatiche ed attenzione alle esigenze dell'utenza più svantaggiata si dispongono al ricevimento con modalità e resistenze psicologicamente rassicuranti.

The twist reception consists of systems organised for two types of use: the central type, defined by one or more circular "operative segments" or linear elements, obtained by joining basic operational sections; these are made of panels obtained by overlapping straight or shaped staves of various colours, on which glass tables and worktops are installed.

These are "islands or fronts" for relations which, thanks to the shape, chromatic characteristics and meticulous attention to the needs of users even with special requirements, create a reception area sure to put everyone at their ease.

L'accueil Twist comprend des postes de travail organisés selon deux typologies d'usage: un type circulaire, défini par un ou plusieurs éléments ronds ou "quartiers des opérations", et un type linéaire, qui résultent de la combinaison de sections élémentaires d'activité. Ces postes sont donc constitués de panneaux obtenus par la superposition de lattes droites ou façonnées de couleurs différentes, qui servent de support à des plateaux de service en verre, et à des plans de travail.

Il s'agit d'îlots ou de comptoirs conviviaux, qui étant donné leur forme, leurs caractéristiques chromatiques et l'attention que nous accordons aux exigences des usagers porteurs de handicap, sont conçus de manière à faciliter un accueil en toute sérénité.

Die Twist-Rezeption besteht aus Bereichen, die entsprechend zwei Benutzungstypologien organisiert sind: der zentrische Typ, bestehend aus einem oder mehreren kreisförmigen Elementen „Tätigkeitssegmenten“ oder der lineare Typ, der sich aus der Verbindung von elementaren Tätigkeitsabschnitten zusammensetzt; sie sind aus Platten angefertigt, die aus der Überlagerung von geraden oder geformten, farblich unterscheidbaren Lamellen gewonnen werden, an denen Abstellflächen aus Glas und Arbeitsflächen befestigt sind.

Sie stellen „Inseln oder Fronten“ des Beziehungsaufbaus dar, die sich durch die Form, die Farbeigenschaften und die Aufmerksamkeit für die Bedürfnisse des behinderten Benutzerkreises, mit einer Festigkeit und auf eine Weise präsentieren, die psychologisch Vertrauen erweckend wirken.

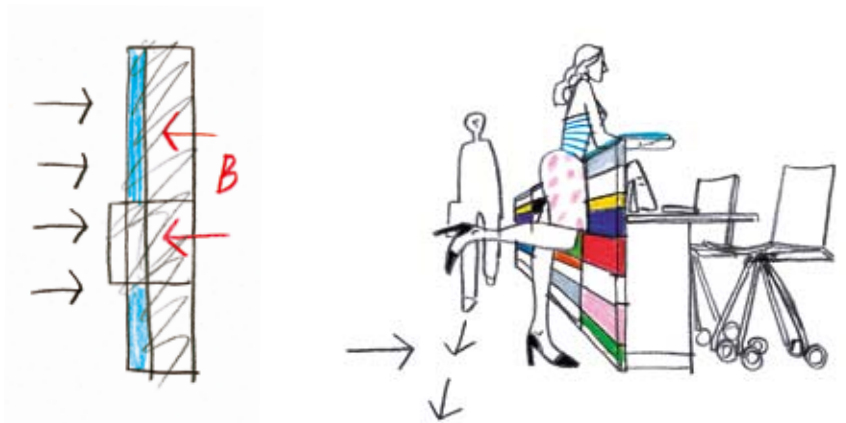

ACCOGLIENZA / RECEPTION
ACCUEIL / REZEPTION

TWIST

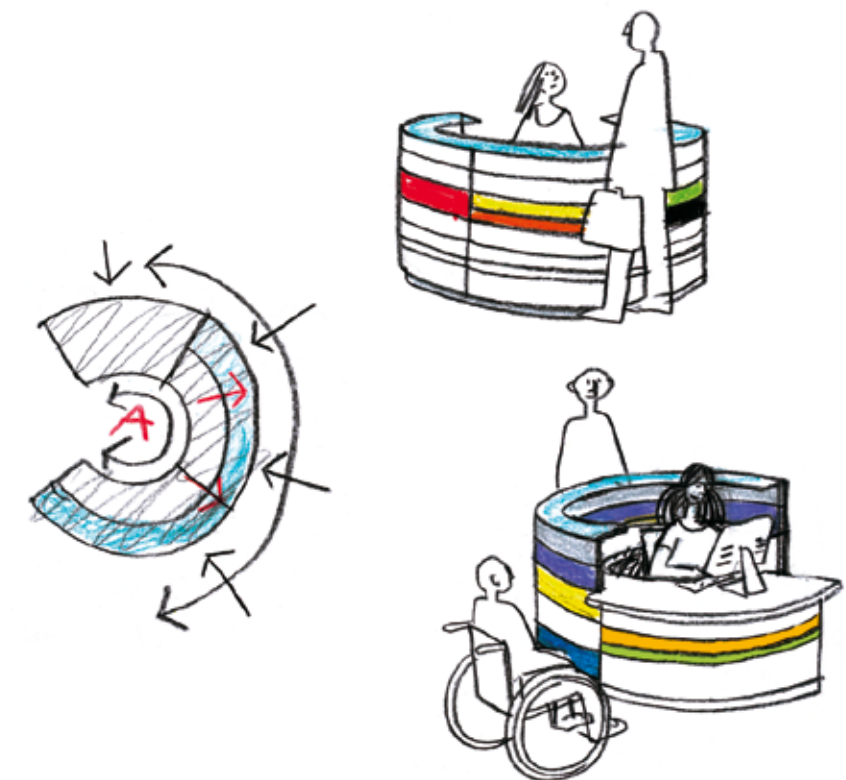



"Isole di relazione" per ricevere e presentarsi con disponibilità e cortesia.
"Islands for relations" to welcome visitors and present the company in a
receptive and courteous way.
Îlots de convivialité pour recevoir et se présenter avec disponibilité et
courtoisie.
„Beziehungsareale“, um zu empfangen und sich entgegenkommend und
mit Höflichkeit vorzustellen.





twit
4 5



Predisposti all'integrazione delle reti elettrica ed informatica e connotati dalla possibilità di regolare la posizione degli schermi in altezza dei computer sui piani di lavoro, essi costituiscono fronti cromaticamente espressivi e funzionalmente efficienti a cui avvicinarsi con fiducia.

Ready for the integration of electrical and computer systems, with the possibility of adjusting the position and height of the computer screen on the desk, these elements create chromatically expressive and practical fronts it's a pleasure to walk up to.

Conçus pour l'intégration des réseaux électrique et informatique, ces postes sont caractérisés par leur possibilité de régler la hauteur des écrans d'ordinateur sur les plans de travail. Ce sont des façades expressives au niveau chromatique, elles sont efficaces au niveau fonctionnel et elles inspirent la confiance.

Ausgestattet für die Integration von Strom- und Datenetzen und von der Möglichkeit gekennzeichnet, die Position der Bildschirme entsprechend der Höhe der Computer auf den Arbeitsflächen zu regulieren, formen sie farblich ausdrucksvolle und funktionell leistungsfähige Fronten, denen man sich vertrauensvoll nähert.

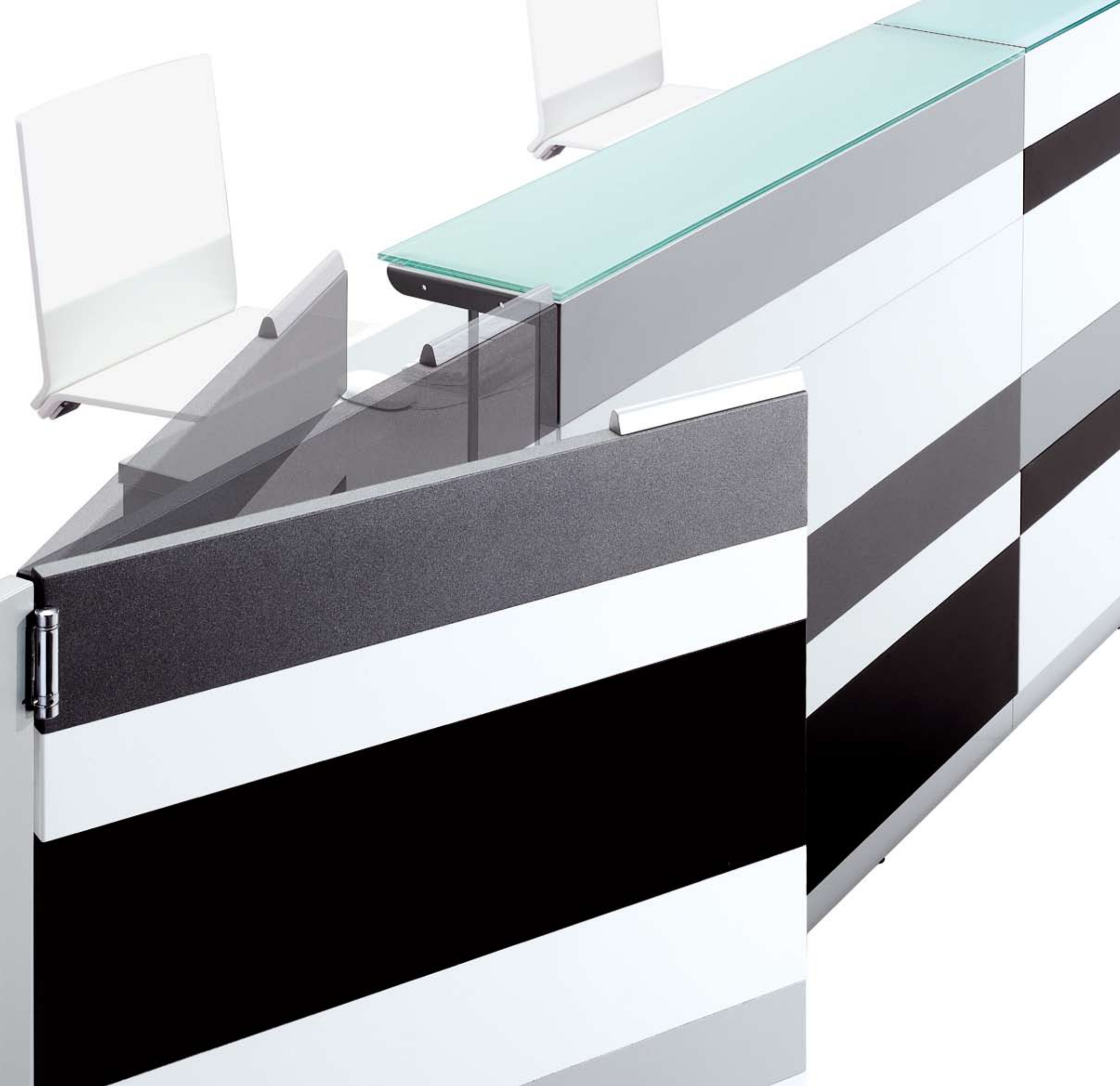



I contenitori twist sono elementi di arredo utili ad ordinare, contenere ed archiviare il lavoro.
 Sono costituiti da pannelli piani o curvi ottenuti dalla sovrapposizione di doghe dritte o sagomate, cromaticamente differenziabili, a cui sono vincolati montanti strutturali che sostengono mensole d'uso.
 Utilizzati come muri colorati o cabine di servizio, essi intervengono nello spazio ufficio con autonomia espressiva definendo luoghi di lavoro dinamici in cui liberamente muoversi ed identificarsi.

The twist storage units are furnishing elements extremely useful for keeping things in order, providing storage and filing space at work.
 They consist of flat or curved panels obtained by overlapping straight or curved staves of various colours, where the structural uprights that support the shelves are fixed.
 Used as coloured walls or service cabins, these become part of the office space with an autonomy of expression, to create dynamic workplaces in which people can move freely and express their own identity.

Les éléments de rangement Twist sont des structures d'ameublement utiles pour ranger, contenir et classer le travail.
 Ils sont constitués de panneaux plats ou curvilignes, obtenus par la superposition de lattes droites ou façonnées de couleurs différentes, sur lesquels se greffent des montants structurels qui servent de support à des étagères.
 Utilisés comme cloisons colorées ou cabines de service, ils interviennent dans l'espace bureau avec leur autonomie d'expression, en définissant des lieux de travail dynamiques où vous pourrez vous déplacer et vous identifier librement.

Die Twist-Container sind zweckmäßige Einrichtungsgegenstände, die helfen die Arbeit zu ordnen, unterzubringen und zu archivieren.
 Sie bestehen aus flachen oder gebogenen Platten, die aus der Überlagerung von geraden oder geformten, farblich unterscheidbaren Lamellen gewonnen werden, an denen strukturelle Pfeiler verankert sind, die Abstellflächen tragen.
 Als bunte Wände oder Kabinen eingesetzt, greifen sie mit Ausdrucksautonomie in den Büroraum ein, dynamische Arbeitsplätze definierend, an denen man sich frei bewegen und mit denen man sich identifizieren kann.

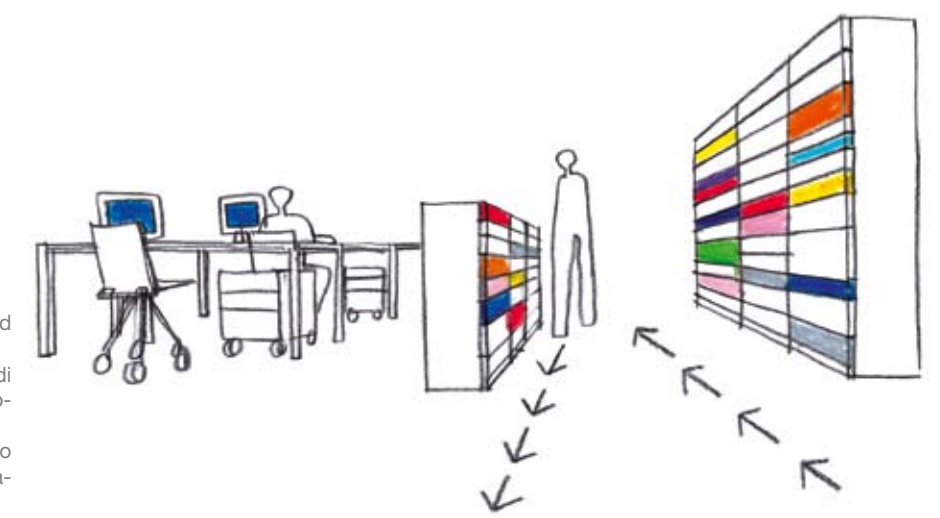

CONTENITORI / STORAGE UNITS
 ÉLÉMENTS DE RANGEMENT / CONTAINER **twist**

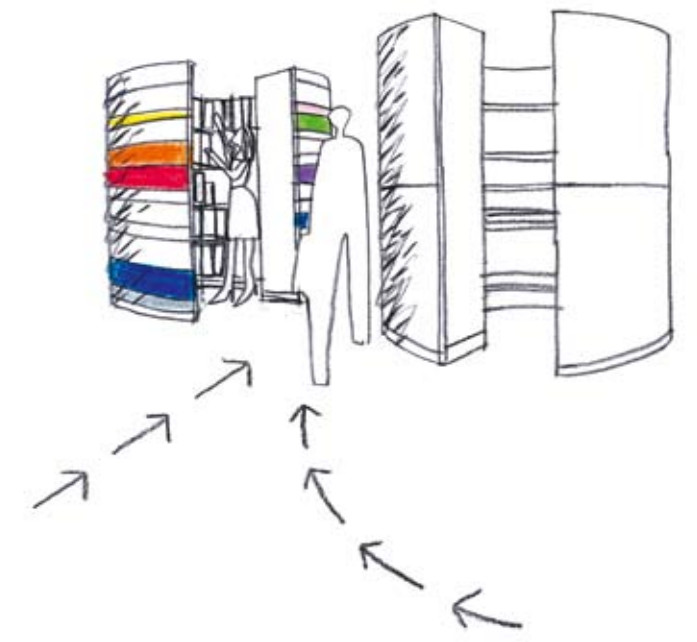







Contenitori contrapposti, definendo percorsi colorati o corridoi archivio, realizzano funzionali ed interessanti suddivisioni dello spazio ufficio.
 Opposing storage units, creating coloured paths or archive corridors, creating practical and interesting partitions of the office space.
 Ces éléments de rangement antagonistes définissent des parcours colorés ou des couloirs destinés au classement, et ils réalisent des séparations fonctionnelles et intéressantes de l'espace bureau.
 Gegenüberstehende Container, die farbige Gänge oder Archivflure definieren, führen zu funktionellen und interessanten Unterteilungen des Büroraumes.





I contenitori "cabina" sono una nuova tipologia di arredo e di organizzazione del lavoro che, posizionati liberamente nell'ambiente ufficio, permettono di realizzare aree di operatività efficienti e fluidamente relazionate.

The "cabin" storage units are a new type of furnishing element and a new way of organizing the workspace which, placed freely in the office environment, let you create efficient operating areas with fluid relations between operators.

Les éléments de rangement en forme de cabine sont une nouvelle typologie d'ameublement et d'organisation du travail qui, positionnés librement dans l'environnement bureau, permettent de réaliser des espaces d'activité efficaces et fluides au niveau de la convivialité.

Die „Kabinen“-Container sind eine neue Arbeitsorganisations- und Einrichtungstypologie, die es, frei positioniert, im Bürobereich möglich machen, leistungsfähige und in fließender Beziehung stehende Bereiche zu realisieren.





Contentori sinuosi accompagnando ed orientando i percorsi definiscono nuove modalità d'uso dello spazio ufficio.
Sinuous storage units follow and direct the way people move in the environment, defining new ways to use the office space.
Ces éléments de rangement sinueux accompagnent et orientent les parcours, en définissant de nouvelles modalités d'usage de l'espace bureau.
Kurvige Container, die mit den Verlaufslinien einhergehen und sie leiten, definieren eine neue Gebrauchsart des Büroraumes.



twist
22 23



Le postazioni operative twist sono "isole di attività" singole o multiple. Esse sono costituite dall'unione di elementi circolari a pannello e a scrivania, "spicchi operativi" che dispongono il lavoro intorno all'operatore. La loro particolare organizzazione permette la concomitante definizione di ambiti di operatività protetta e di apertura alle stimolazioni dell'intorno. In composizione sistemica realizzano "arcipelaghi operativi" dinamici e funzionali.

The twist operating stations are single or multiple "islands of activity". They are created by joining circular panel elements and desks, "operative segments" to lay out the work around the operator. The particular organisation makes it possible to define protected operating zones and areas open to the feedback of the people in the area, at the same time. In a modular composition, they can be used to create dynamic and practical "operative archipelagos".

Les postes de travail modulaires Twist sont des îlots d'activité individuels ou multiples. Ils se combinent par l'association d'éléments circulaires équipés de panneaux et de tables bureaux, des "quartiers opérationnels" qui disposent le travail autour de l'opérateur. Leur organisation particulière permet de définir simultanément des habitats d'activité protégés, tout en étant ouvert aux dynamismes qui gravitent autour. En composition modulaire, ces postes de travail forment des "archipels opérationnels" dynamiques et fonctionnels.

Die Twist-Arbeitsbereiche sind einzelne oder vielfache „Arbeitsinseln“. Sie bestehen aus der Verbindung von kreisförmigen Platten- und Schreibtischelementen „Tätigkeitssegmenten“, die die Arbeit um den Arbeitenden herum anordnen. Ihre besondere Einteilung macht aus ihnen Bereiche, die sowohl abgeschirmte Tätigkeiten als auch Offenheit für die umgebenden Stimulierungen erlauben. Sie verwirklichen in systematischer Zusammensetzung dynamische und funktionelle „Tätigkeitskomplexe“.

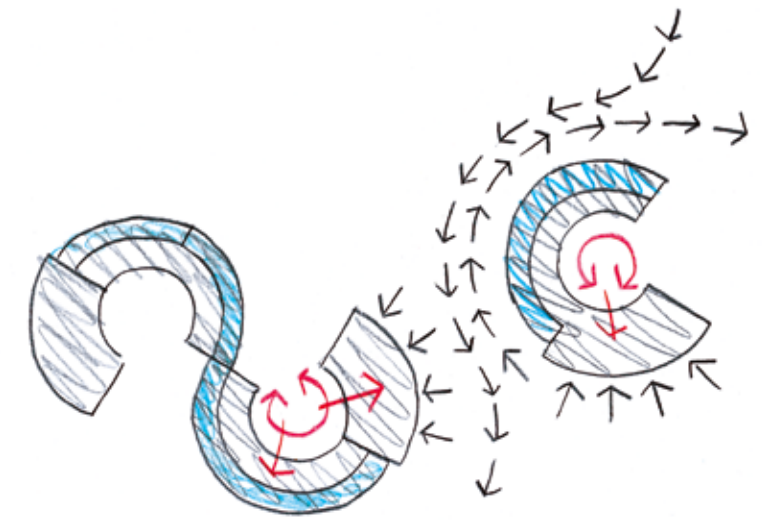

POSTAZIONI / OPERATING STATIONS / POSTES DE TRAVAIL MODULAIRES / ARBEITSBEREICHE

twist

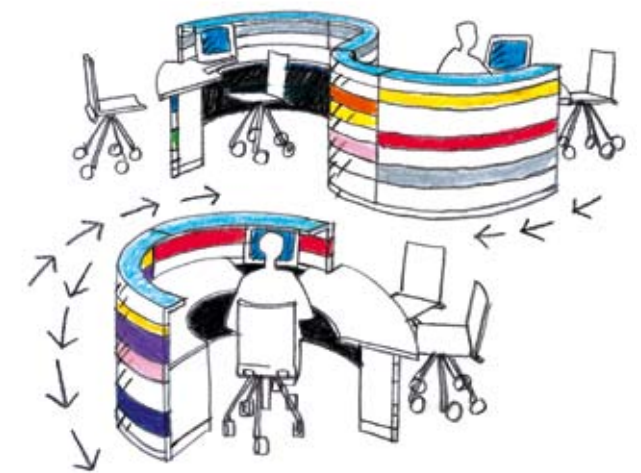





Luoghi di lavoro dinamici conformati al movimento delle idee dei progetti e delle relazioni.
Dynamic workplaces that adapt to changing design ideas and relations.
Lieux de travail dynamiques, qui s'adaptent au dynamisme des projets et des relations.
Dynamische Arbeitsbereiche, die der Mobilität der Projektideen und der Beziehungen angepasst sind.



La ricreazione twist è costituita da elementi di arredo dedicati alle pause del lavoro.

Il bar è una postazione di ristoro definita dall'unione di elementi circolari costituiti da pannelli ottenuti dalla sovrapposizione di doghe sagomate, cromaticamente differenziabili, ai quali sono vincolati piani di lavoro e sovralzati in vetro.

Carrelli di servizio, quali contenitori frigorifero, per i rifiuti e dispensa, posizionabili al di sotto del piano operativo dotato di lavello, permettono il funzionale esercizio della postazione.

Sedute alte e tavolini nominati "oliver" completano il sistema definendo simpatiche aree di pausa.

Twist recreation consists of furnishing elements dedicated to breaks from work.

The bar is a place for refreshments, created by joining circular panel elements obtained by overlapping shaped staves of various colours, to which the worktops and glass risers are fixed.

Service trolleys, such as refrigerator units, waste bins and food storage units, can be put under the worktop with its sink, making the counter extremely practical to use.

High seating arrangements and "Oliver" tables complete the system, creating welcoming areas to take your break.

La récréation Twist est constituée de structures d'ameublement destinées aux pauses de travail.

Le bar est un poste de restauration défini par la combinaison d'éléments circulaires constitués de panneaux obtenus par la superposition de lattes droites ou façonnées de couleurs différentes, qui servent de support à des plans de travail et à des tablettes en verre.

Les chariots de service contiennent éventuellement un réfrigérateur, une poubelle ou le garde-manger. Ils peuvent être positionnés en-dessous du plan de travail équipé d'un évier, ce qui permet ainsi un exercice fonctionnel de ce poste.

Des chaises hautes et les petites tables OLIVER complètent ce système pour définir des coins sympatiques pour faire la pause.

Der Twist-Pausenbereich besteht aus Einrichtungsgegenständen, die den Arbeitspausen gewidmet sind.

Die Bar ist ein Imbissbereich, der aus der Verbindung von kreisförmigen Elementen gebildet wird, die aus Platten bestehen, welche aus der Überlagerung von geformten, farblich unterscheidbaren Lamellen gewonnen werden, an denen Arbeitsflächen und Aufsätze aus Glas verankert sind.

Wagen, die als Kühlschrank-, Abfall- und Vorratscontainer fungieren, sind unter der, mit einem Waschbecken ausgestatteten, Arbeitsfläche positionierbar und machen einen funktionellen Betrieb des Bereiches möglich. Hohe Sitzmöglichkeiten und „Oliver“ genannte Tische vervollständigen das System, indem sie nette Pausenbereiche bilden.

RICREAZIONE / RECREATION
RÉCRÉATION / PAUSENBEREICH

twist



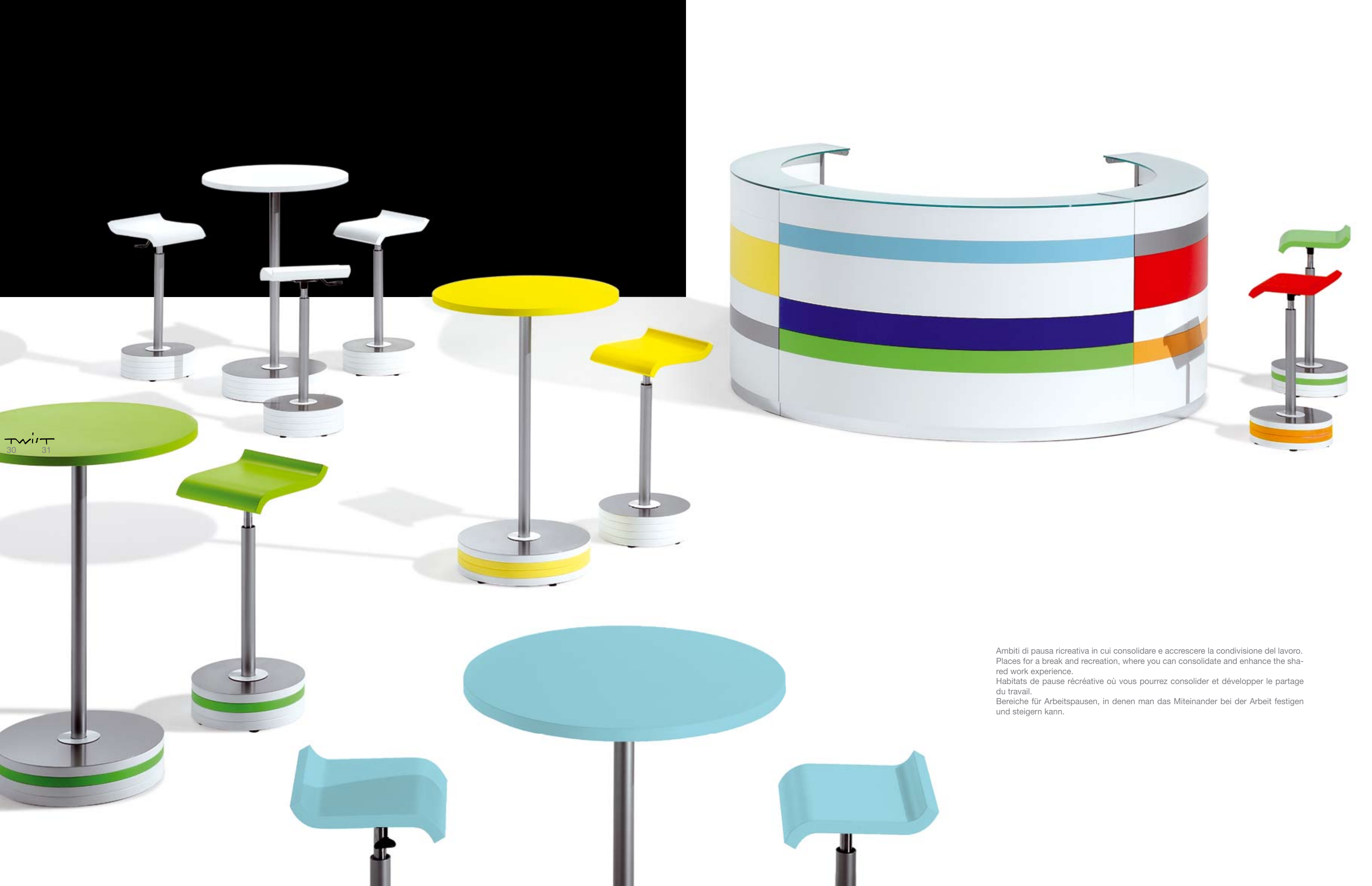

twist
30 31

Ambiti di pausa ricreativa in cui consolidare e accrescere la condivisione del lavoro.
Places for a break and recreation, where you can consolidate and enhance the shared work experience.
Habitats de pause récréative où vous pourrez consolider et développer le partage du travail.
Bereiche für Arbeitspausen, in denen man das Miteinander bei der Arbeit festigen und steigern kann.





Postazioni che si possono riempire di colori.
Work stations that come alive with colour.
Postes de travail que vous pouvez remplir de couleurs.
Bereiche, die mit Farben ausgefüllt werden können.



Round one



Round six



Round two



Round seven



Round three



Round eight



Round four



Round nine



Round five



Round ten



Straight one



Straight four



Straight two



Straight five



Straight three



Straight six

Twist (H - L - P)

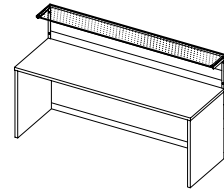

BT0800V 106 - 80 - 63
BT1200V 106 - 120 - 63
BT1400V 106 - 140 - 63
BT1600V 106 - 160 - 63
BT1800V 106 - 180 - 63

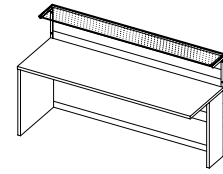

BT0801V 106 - 80 - 63
BT1201V 106 - 120 - 63
BT1401V 106 - 140 - 63
BT1601V 106 - 160 - 63
BT1801V 106 - 180 - 63

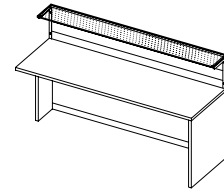

BT0802V 106 - 80 - 63
BT1202V 106 - 120 - 63
BT1402V 106 - 140 - 63
BT1602V 106 - 160 - 63
BT1802V 106 - 180 - 63

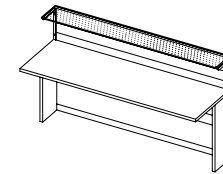

BT0803V 106 - 80 - 63
BT1203V 106 - 120 - 63
BT1403V 106 - 140 - 63
BT1603V 106 - 160 - 63
BT1803V 106 - 180 - 63

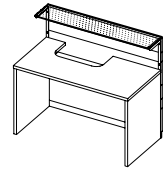

BT1200C1 106 - 120 - 63
BT1201C1 106 - 120 - 63
BT1202C1 106 - 120 - 63
BT1203C1 106 - 120 - 63

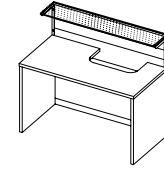

BT1200C2 106 - 120 - 63
BT1201C2 106 - 120 - 63
BT1202C2 106 - 120 - 63
BT1203C2 106 - 120 - 63

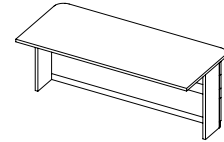

BT080F 73 - 80 - 80
BT120F 73 - 120 - 80
BT140F 73 - 140 - 80
BT160F 73 - 160 - 80
BT180F 73 - 180 - 80

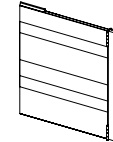

BT1 100 - 70÷90 - 3

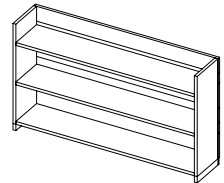

BT080/63 104 - 80 - 38
BT120/63 104 - 120 - 38
BT140/63 104 - 140 - 38
BT160/63 104 - 160 - 38
BT180/63 104 - 180 - 38

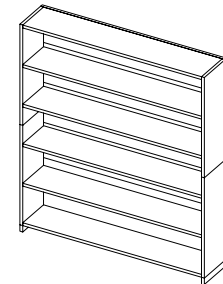

BT080/73 202 - 80 - 38
BT120/73 202 - 120 - 38
BT140/73 202 - 140 - 38
BT160/73 202 - 160 - 38
BT180/73 202 - 180 - 38

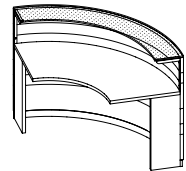

BT090EV 106 - 163 - 63
BT091EV 106 - 163 - 63
BT092EV 106 - 163 - 63

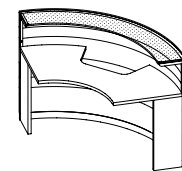

BT090CV 106 - 163 - 63
BT091CV 106 - 163 - 63
BT092CV 106 - 163 - 63

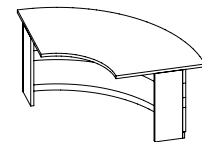

BT090F 73 - 190 - 80
BT091F 73 - 190 - 80
BT092F 73 - 190 - 80

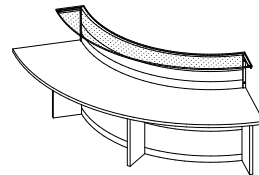

BT090IV 106 - 247 - 63

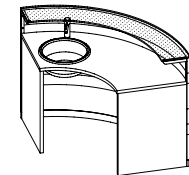

BT090LV 106 - 163 - 63
BT091LV 106 - 163 - 63
BT092LV 106 - 163 - 63

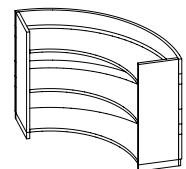

BT090/63E 104 - 163 - 38

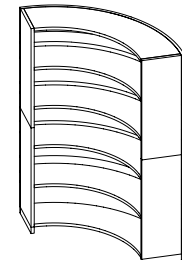

BT090/73E 202 - 163 - 38

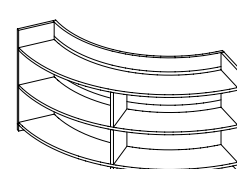

BT090/63I 104 - 247 - 38

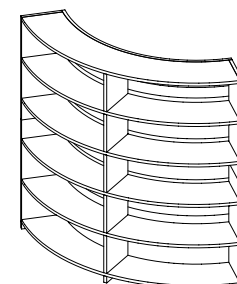

BT090/73I 202 - 247 - 38

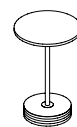

OLIVER2 105 - ø - 70



OLIVER 70/83 - 36 - 36

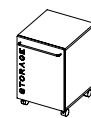

BT045S 67 - 45 - 50

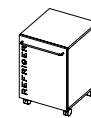

BT045R 67 - 45 - 50



BT045W 67 - 45 - 50

organizzazione lineare / linear arrangement

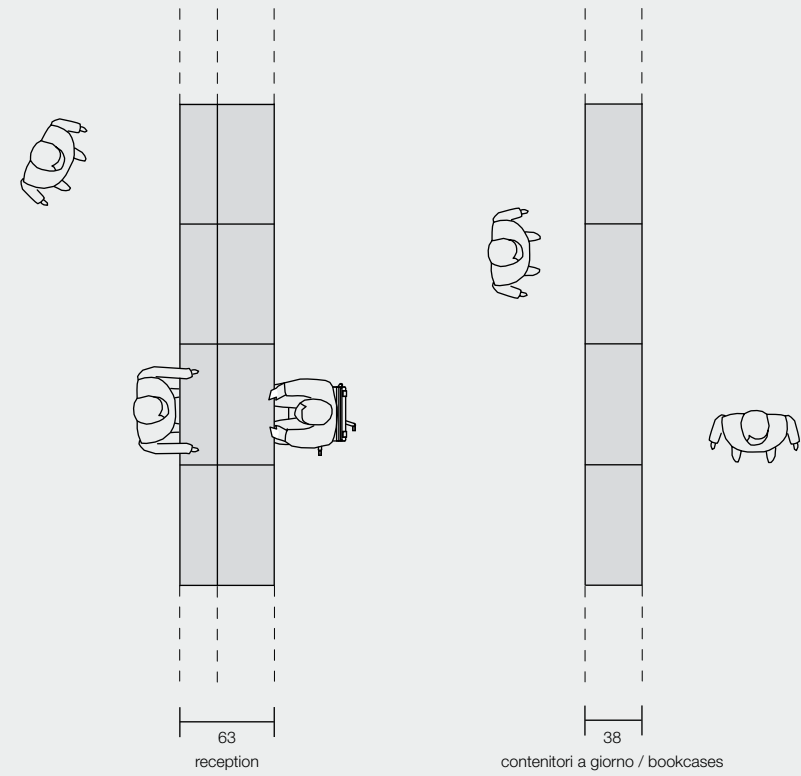

organizzazione circolare / circular arrangement

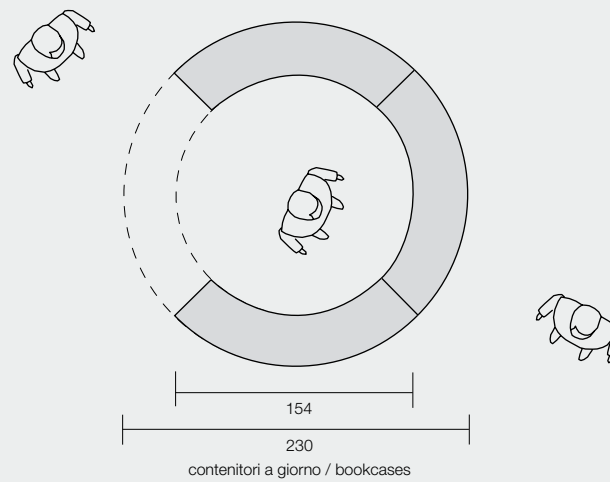
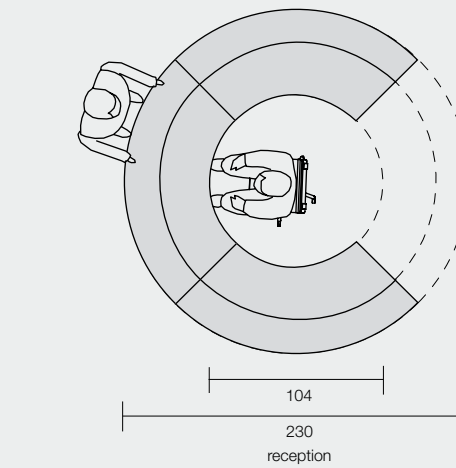

Pannelli sovrapposti / Overlapping panels / Panneaux superposés / Überlagerte Platten

Pannelli / Panels / Panneaux / Platten

A12	B12	C12
A11	B11	C11
A10	B10	C10
A9	B9	C9
A8	B8	C8
A7	B7	C7
A6	B6	C6
A5	B5	C5
A4	B4	C4
A3	B3	C3
A2	B2	C2
A1	B1	C1

Buon progetto! / Enjoy your project. / Dessinez votre propre projet. / Viel Spaß beim Entwerfen!

TWIST

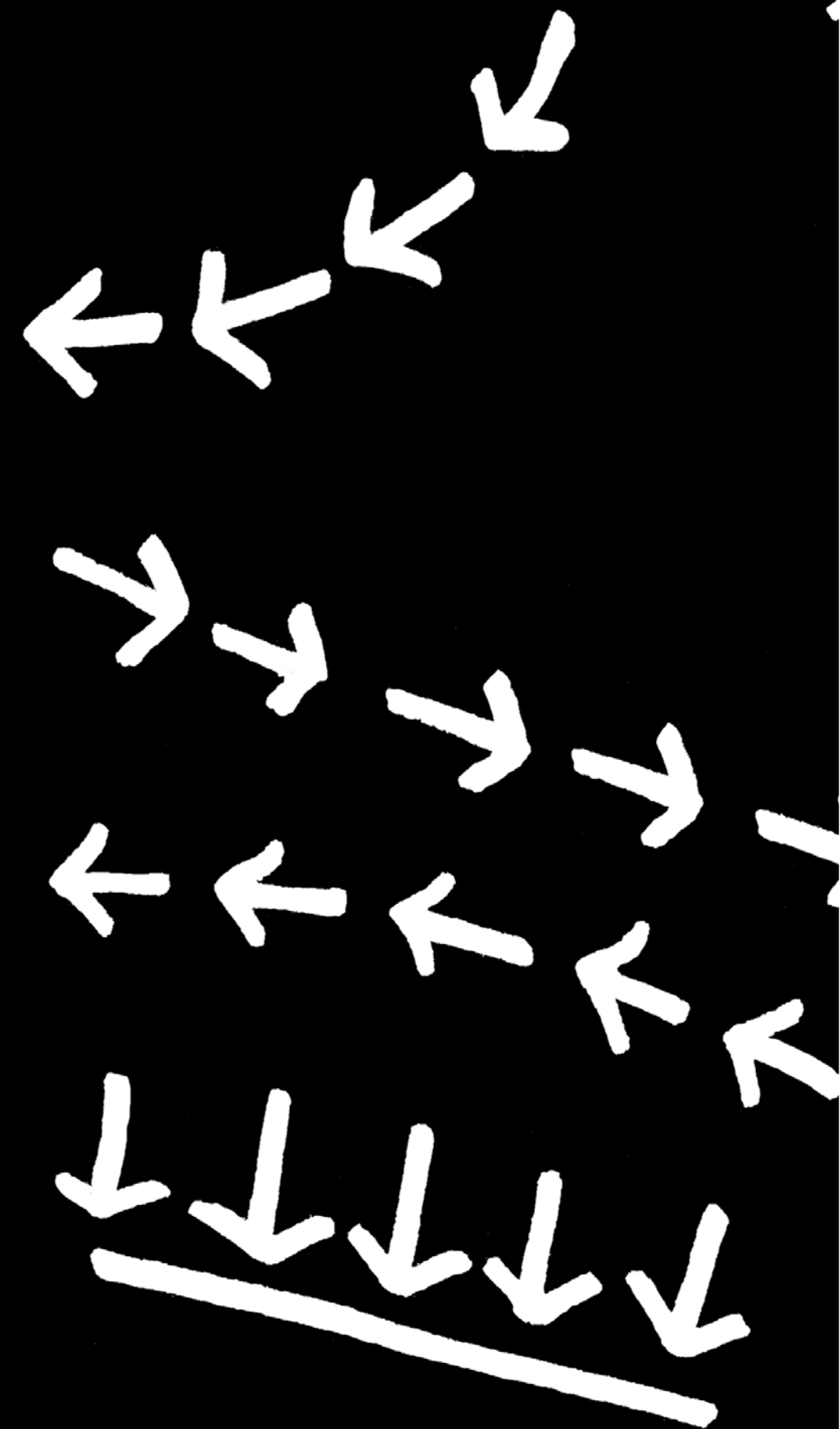

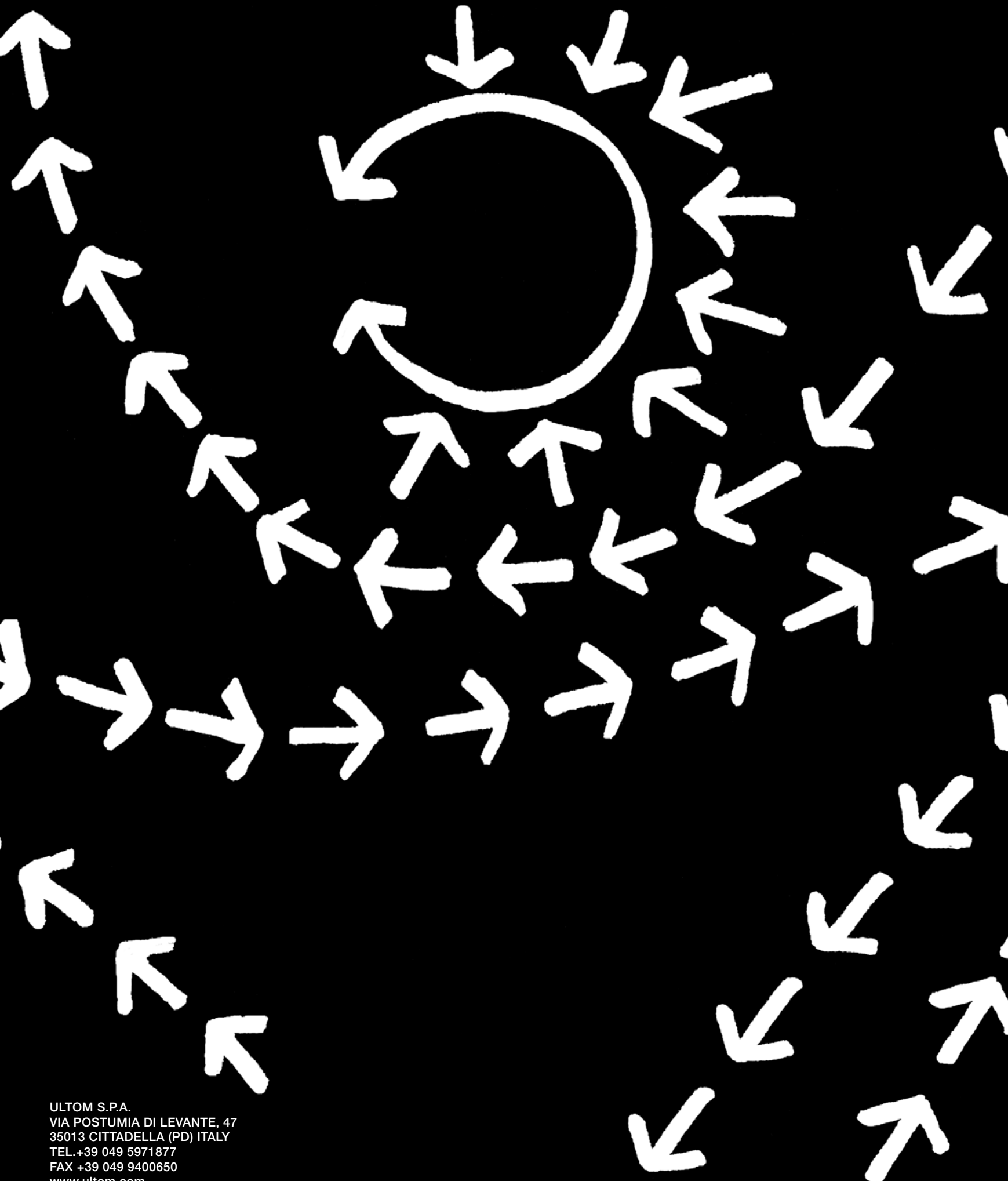

ULTOM S.P.A.
VIA POSTUMIA DI LEVANTE, 47
35013 CITTADELLA (PD) ITALY
TEL. +39 049 5971877
FAX +39 049 9400650
www.ultom.com
e-mail: ultom@ultom.com