

STIMEX

FY

FUNNY

SE



IL MINIMALISMO DELLA STRUTTURA PERIMETRALE

in alluminio, il gioco materico e cromatico dei piani sono gli elementi che rappresentano un originale modo di interpretare e vivere lo spazio direzionale. Un progetto dalla forte caratterizzazione e senza limiti compositivi grazie ad una gamma completa di accessori e di complementi d'arredo.

The minimalist structure of the perimeter is made of aluminium, playing with materials and color among the levels to deliver an original way of interpreting and experiencing an executive office. The design boasts a strong sense of character and has endless arrangement options thanks to a full line of accessories and furnishing pieces.

La sobrieté de la structure extérieure en aluminium ainsi que le jeu des matières et des couleurs des plateaux incarnent un espace directionnel interprété et utilisé avec originalité. Un concept de caractère aux possibilités de composition illimitées grâce à une gamme complète d'accessoires et de compléments d'aménagement.









ELEGANTE E RAFFINATO, DUTTILE E COMPLETO

per rileggere l'ambiente executive con personalità. Una proposta con eloquente versatilità compositiva di un sistema creato per risolvere ogni necessità e dare un nuovo stile al lavoro quotidiano

Elegant and refined, flexible and complete, the new Funny+ aluminium leg structure creates a strongly characterized executive environment. A proposal offering eloquent versatility in terms of arrangement.
A system created to address any need and bring a new style to the working day.

Élégante et raffinée, polyvalente et complète, la nouvelle structure avec pieds en aluminium de Funny+ crée un environnement directionnel unique. Une gamme aux possibilités de composition infinies. Un système créé pour répondre avec raffinement à tous les besoins du travail quotidien.





L'ELEGANZA DEI VOLUMI IN ARMONIA CON L'AMBIENTE PRESTIGIOSO.

Una linea executive che si distingue per funzionalità e accostamenti cromatici e materici. La postazione di lavoro è caratterizzata dal volume del mobile di servizio portante e il gioco di riflessi del piano lavoro.

Elegant shapes in harmony with a prestigious space. An executive line distinguished by the functionality of its color and material pairings. The key feature of the workstation is the shape of the base furniture and the playful reflections on the working surface.

L'élégance des volumes en harmonie avec un environnement de prestige. Une gamme professionnelle qui se démarque par la fonctionnalité de ses associations de couleurs et de matériaux. Le poste de travail se distingue par le volume des dessous et le jeu de reflets des plateaux.





FINITURE E SOLUZIONI TECNICHE IN PRIMO PIANO PER DARE IL GIUSTO RISALTO

al progetto globale della collezione. Dettagli di un sistema funzionale per risolvere la connessione del proprio posto lavoro con il mondo. Funzionalità e razionalità; tutti i componenti sono predisposti per alloggiare cablaggi e cavi di alimentazione. Gonne frontali, porta-cpu, gambe intermedia canalizzata per ogni esigenza particolare.

Finishings and technical solutions take center stage to truly celebrate the overall design of the collection. The details of a functional system are used to resolve the connection between one's workstation and the rest of the world. A rational and functional approach: all components offer housings for cables and power cords. Front modesty panels, CPU-caddies, and ducted intermediate legs to satisfy any requirement.

Finitions et solutions techniques de premier ordre mettent parfaitement en valeur le concept global de la collection. Détails d'un système fonctionnel pour reconnecter son poste de travail au monde. Fonctionnalité et rationalité: tous les composants sont conçus pour loger les câbles et les fils d'alimentation. Panneau frontal, desserte pour l'unité centrale, pieds intermédiaires avec logements pour câbles



ESSENZE MELAMINICO SP. 38-18

MELAMINE TYPES TH. 38-18 - ESSENCES MELAMINÉ EP. 38-18



ESSENZE MELAMINICO SP. 25

MELAMINE TYPES TH. 25 - ESSENCES MELAMINÉ EP. 25



METALLO

METAL - MÉTAL

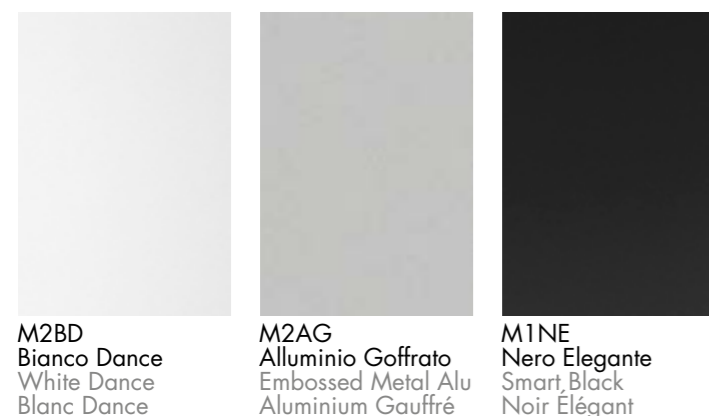

ALLUMINIO

ALUMINIUM - ALUMINIUM

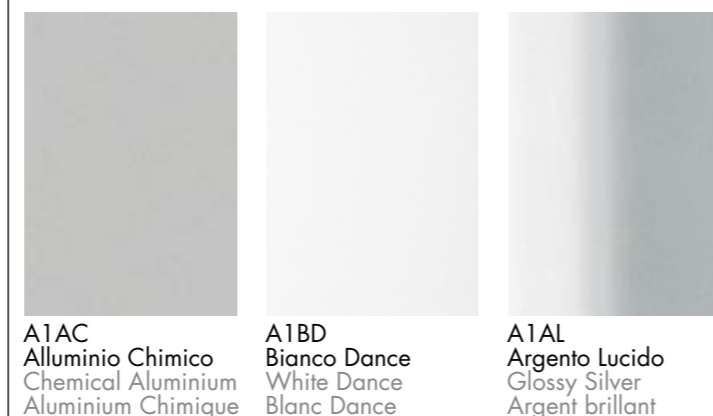

MELAMINICO COLORS SP.18

MELAMINE COLORS - COLEURS MELAMINÉ



METALLO

METAL - MÉTAL

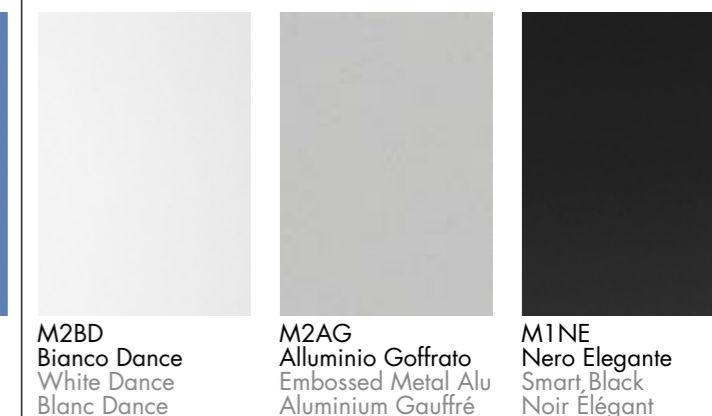

VETRI

GLASSES - VERRES



VETRI

GLASSES - VERRES



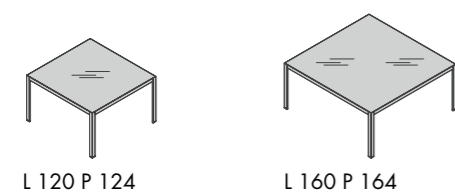
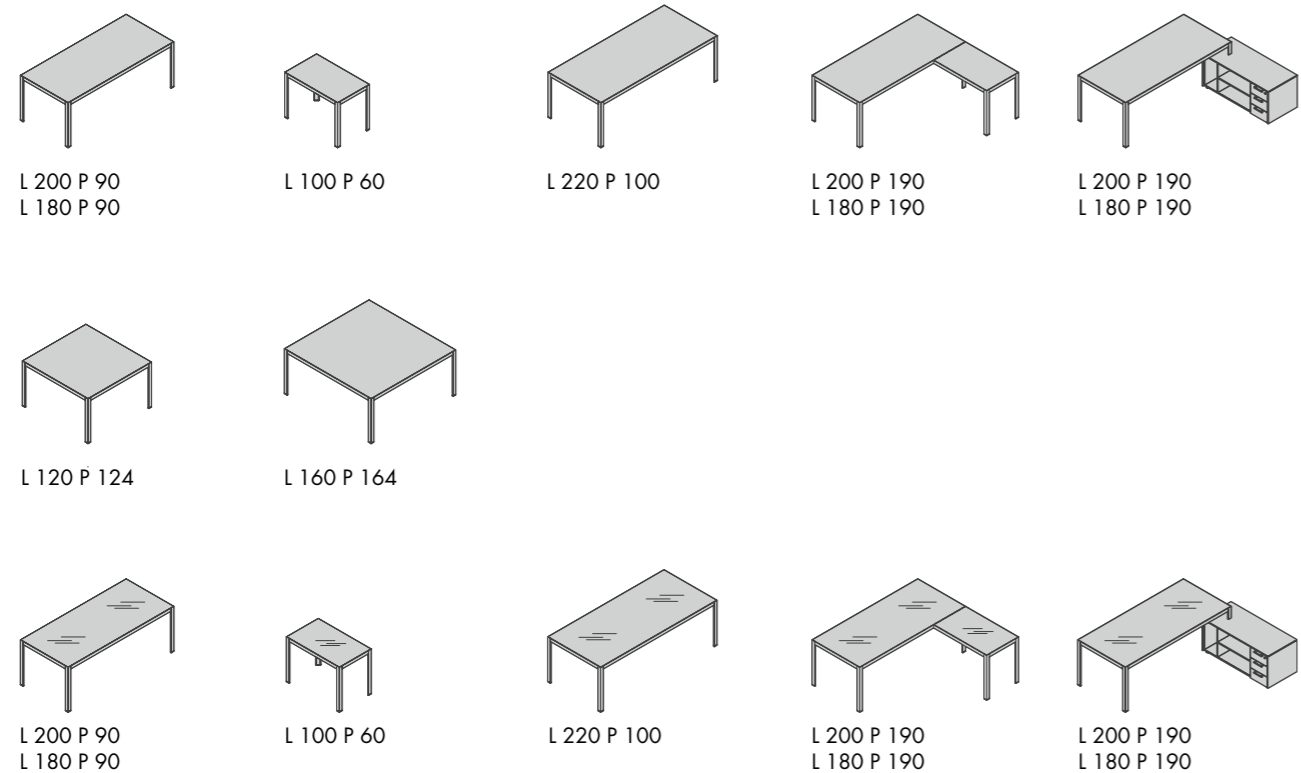
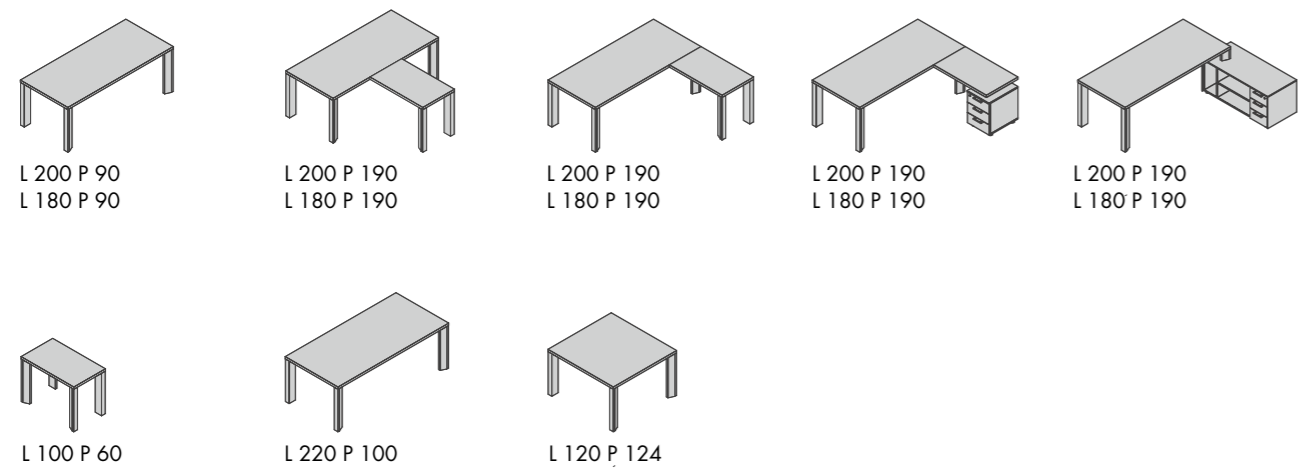
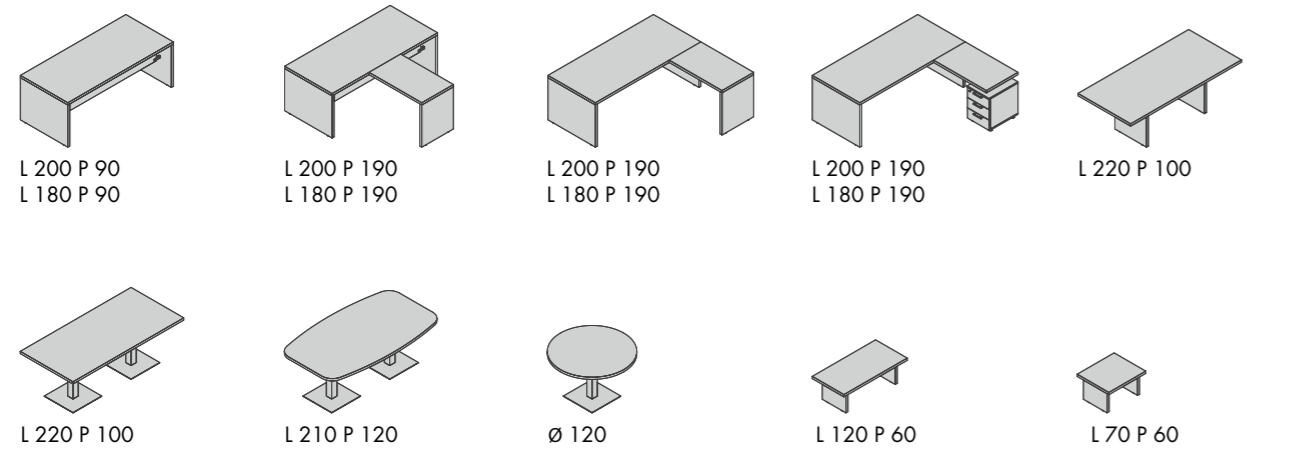

L 120 P 124

L 160 P 164

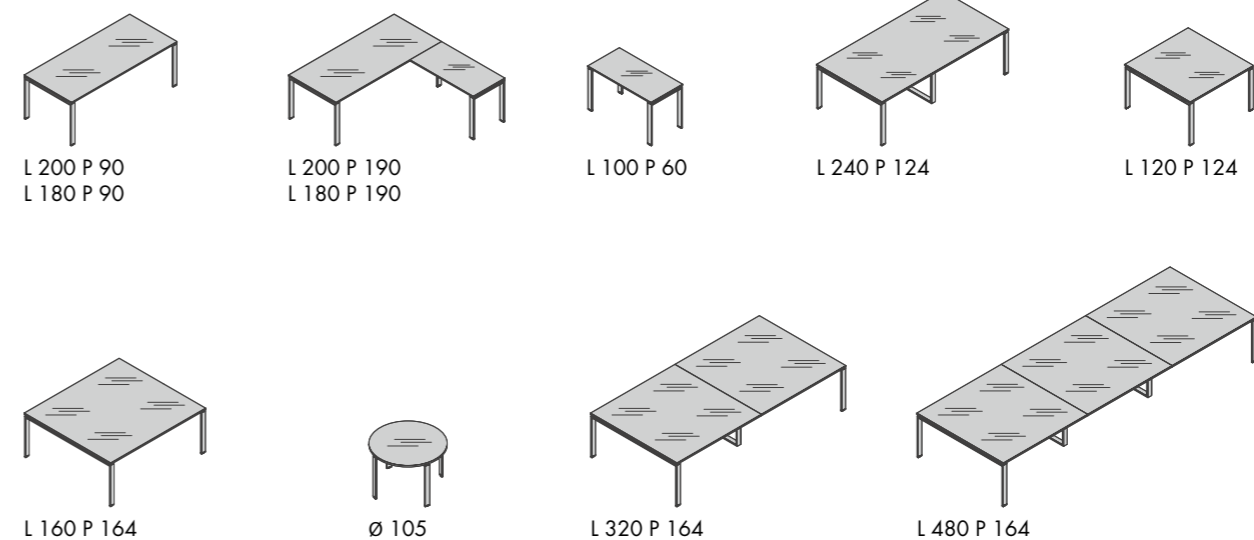
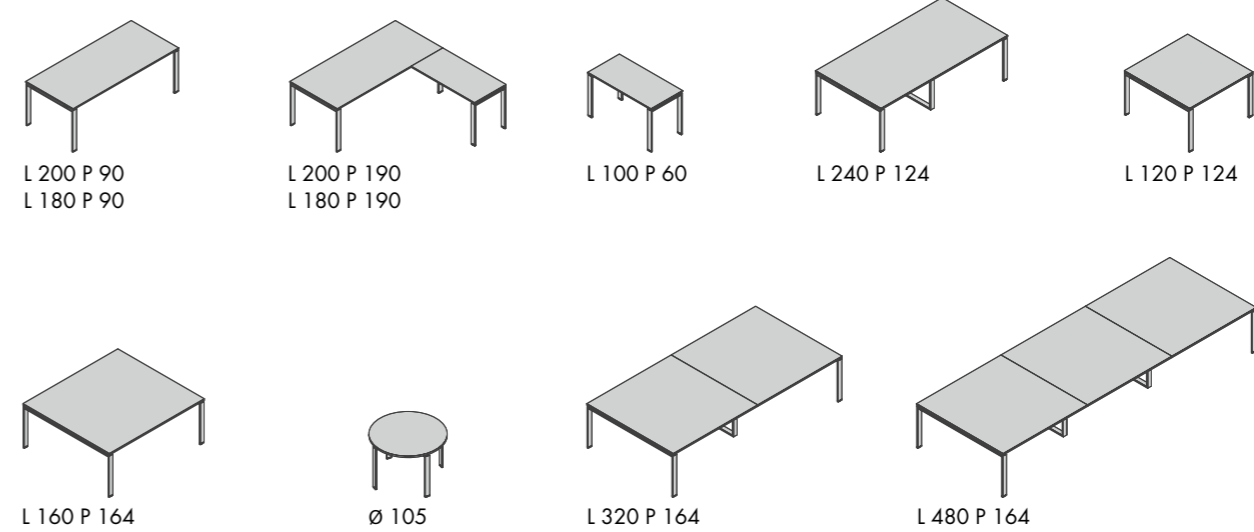
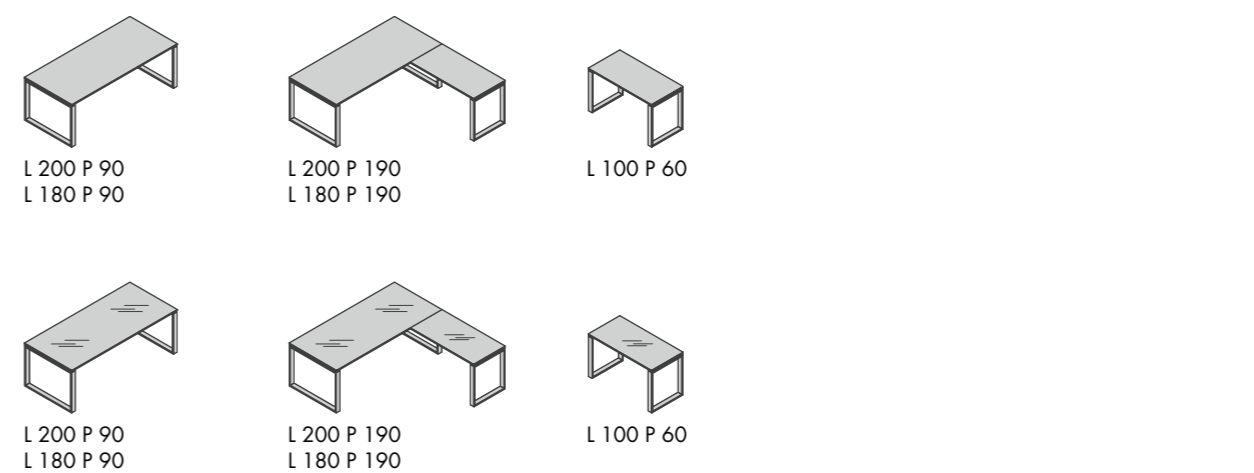

FURNY+|FURNY

