

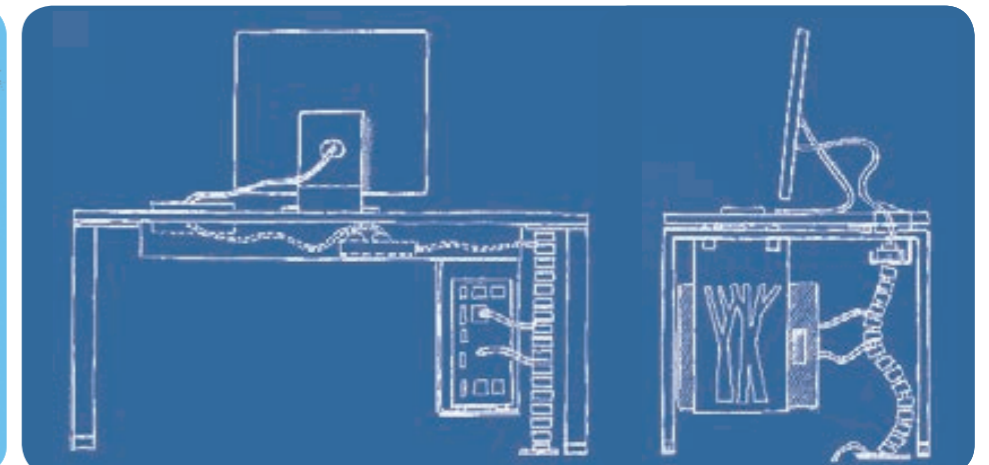

STIMEX

ATREO

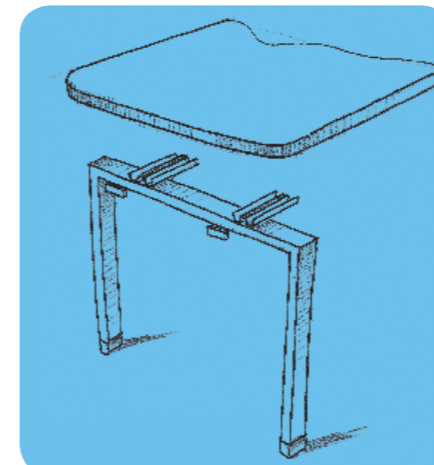

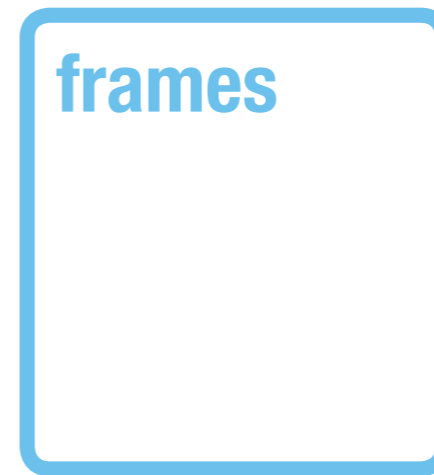
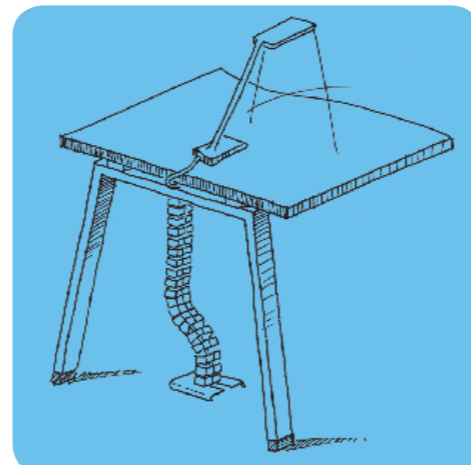
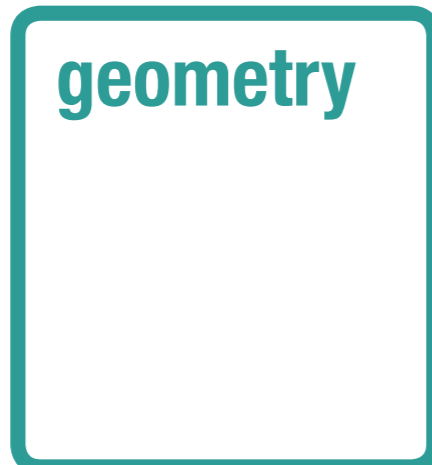
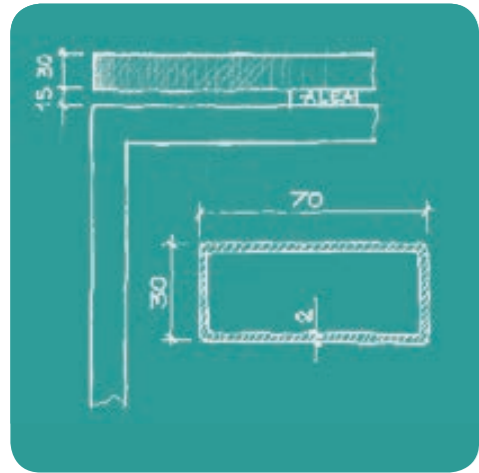
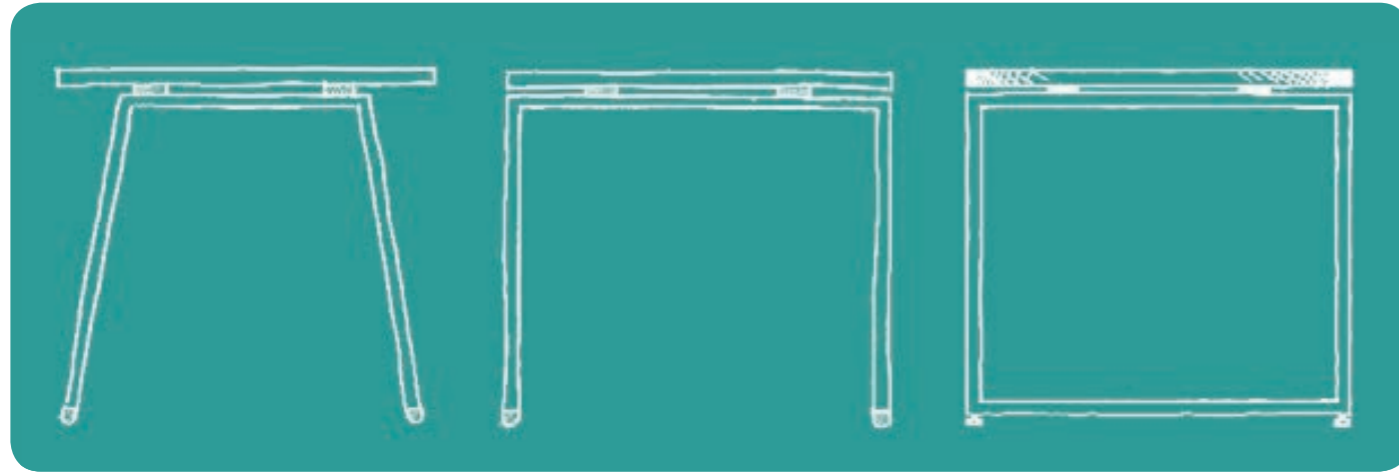

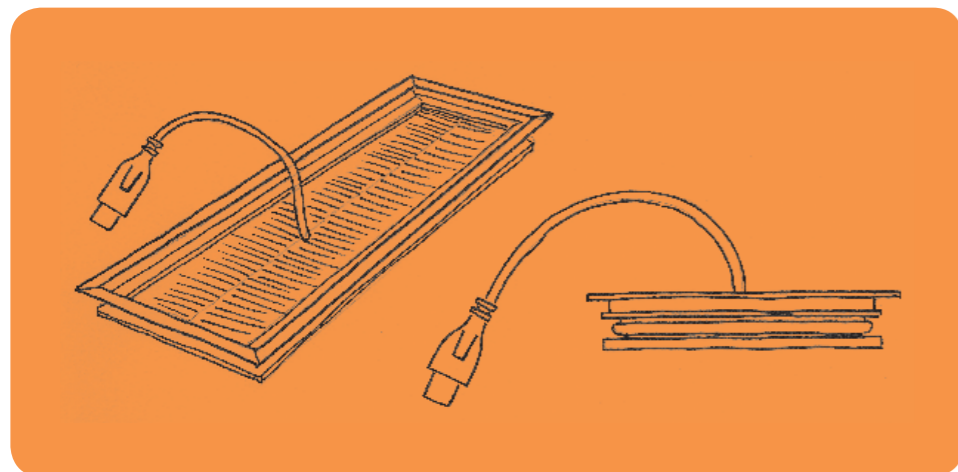
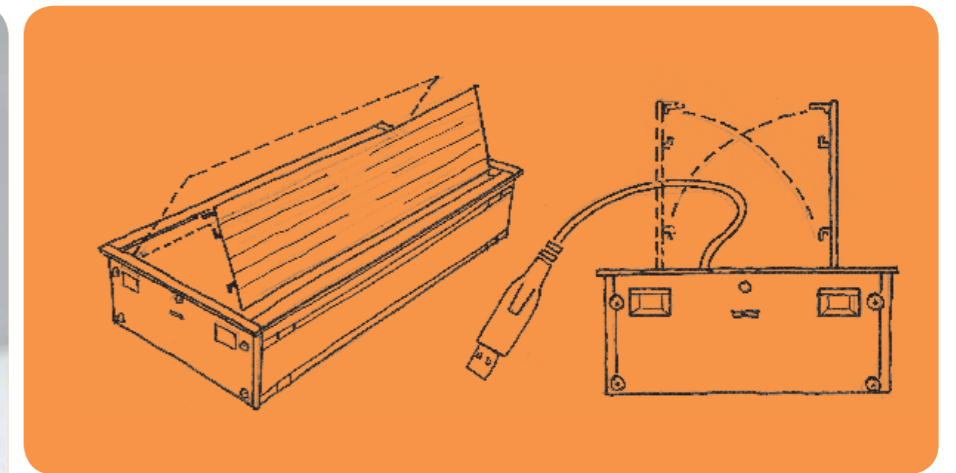
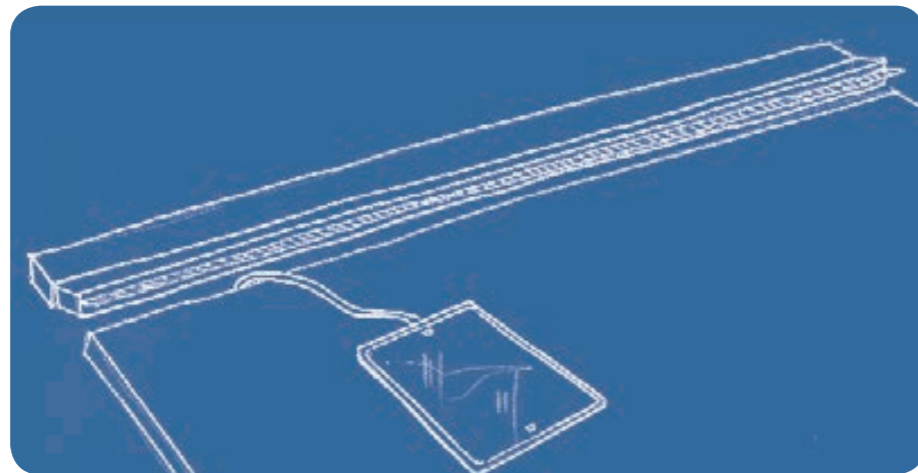
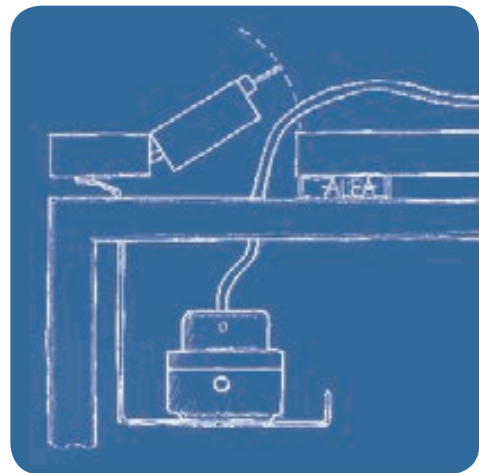
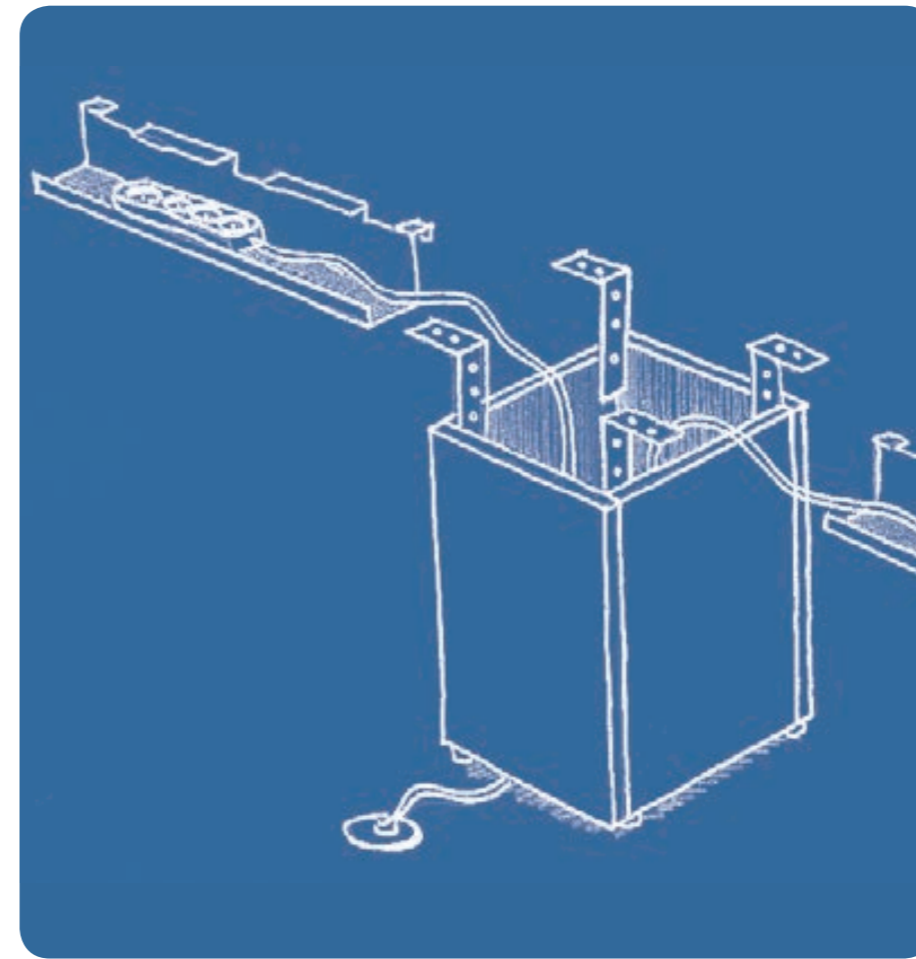
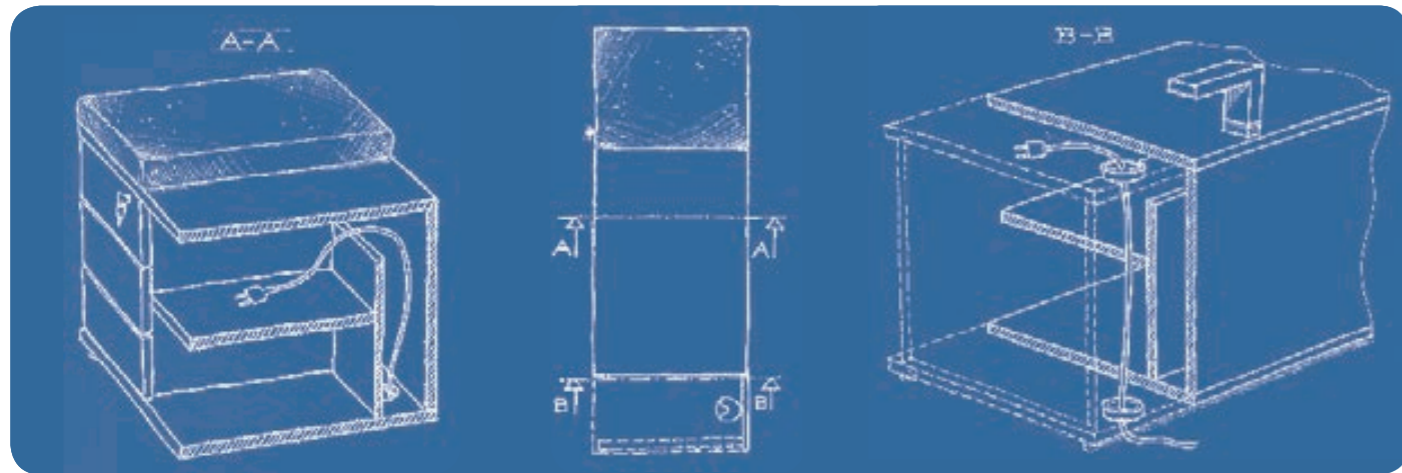

accessories

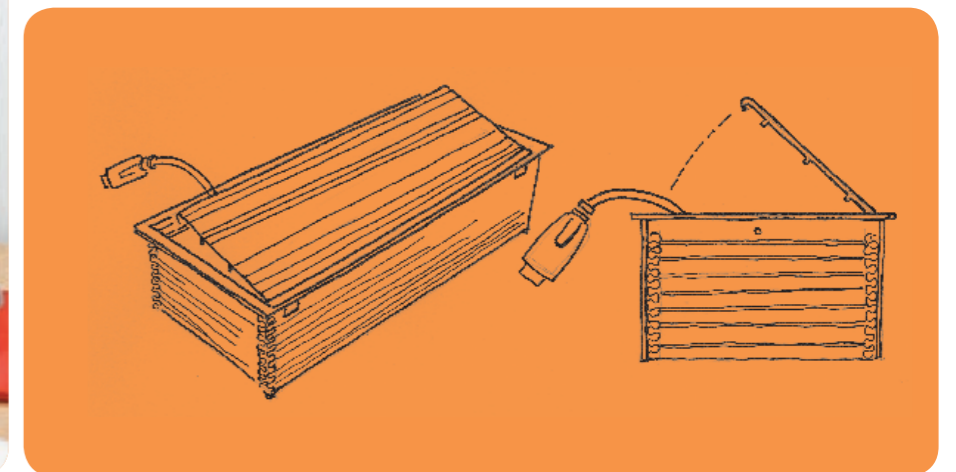

ATREO



6



7







Atreo features also square table tops with rounded corners. In this case the legs are recessed and the suspended returns are offering a more operative solution (the picture shows only the side corners with the curved angles).

Atreo offre également des plans carrés avec des coins arrondis. Les tables en cette option ont comme structure des pieds en retrait et peuvent aussi recevoir des retours accroches. (dans ce cas, le rayon ne concerne que les coins libres).

Atreo también tiene opciones con cubiertas cuadradas y esquinas redondeadas. En este caso las patas están retrasadas y los retornos ofrecen una superficie más operativa. (en la foto el radiado se encuentra en las esquinas libres).



Atreo presenta anche piani quadrati con angoli arrotondati. I tavoli con questa opzione vengono sostenuti da gambe rientranti e possono essere completati da piani dattilo addizionali (in questo caso la raggiatura riguarda solo gli angoli liberi).













ATREO signature feature is the metal leg (straight or angled). The leg supports worktops 30 mm thick (1 3/16") rectangular or shaped. In the benching configurations face to face a center support can replace the intermediate leg and function as a riser to conceal cables and as the ideal location for a floor grommet.

Atreo se caractérise par son pied métallique droit ou incliné qui supporte les plans de travail d'épaisseur de 30mm. Ces plateaux en mélaminé existent en forme compact ou rectangulaire. Plusieurs emplacements existent pour positionner soit un pied intermédiaire, soit un support en mélaminé spécifique pour le stockage des câbles.



ATREO si caratterizza per la gamba metallica a cavalletto (dritta o angolare) a sostegno di piani lavoro in nobilitato melaminico di spessore 30 mm di forma ortogonale o sagomata. Nelle postazioni multiple contrapposte, la gamba intermedia viene sostituita da supporti centrali in melaminico adatti al contenimento dei cavi.

ATREO se caracteriza por su pata puente (recta o a trapezoidal) que soporta las superficies en laminado melamínico de 30mm de grueso, que pueden ser rectas o de formas variadas. En las configuraciones de escritorios múltiples enfrentados la pata intermedia puede ser reemplazada por un soporte central hueco que permite además el manejo de los cables.

ATREO



La gamba di ATREO, realizzata in profilo di metallo verniciato a polveri epossidiche, è disponibile in 10 colorazioni di serie. Al colore della struttura possono essere abbinati gli screen agganciati in metacrilato, le cassettiere e gli armadi con ante piene in melaminico o in metacrilato con telaio in alluminio.

The ATREO leg, made of metal epoxy powder coated, comes in 10 standard colours. Those colours can be combined with matching colours of the acrylic screen, pedestals and storage door fronts.

Le pied métallique Atreo, verni à poudres époxydes, est désormais disponible en 10 couleurs standards. Les écrans, les portes pleines en mélaminé ou en acrylique, les caissons et les accessoires métalliques pourront être assortis à la structure.

La pata estructural de ATREO realizada en acero barnizado con polvos epoxy, está disponible en 10 colores de serie, los cuales se pueden coordinar con las mamparas colgadas acrílicas, las cajoneras y armarios, ya sean de puertas sólidas o con inserciones acrílicas con marco de aluminio.



26



27



The screen dividers are available in different materials: melamine, lacquered, acrylic or tackable fabric with sound absorbing features. The same materials can be applied to fronts and backs of storage cabinets.

Les écrans sont disponibles dans différentes matières: mélaminé, laqué mat, méthacrylate ou encore dans un matériau "tackable" acoustique. Ce dernier peut être appliqué comme revêtement des dos d'armoires ainsi que pour les façades des armoires avec portes coulissantes.

Las mamparas se fabrican en varios materiales y acabados: en laminado melamínico, en aglomerado lacado opaco, en acrílico y también en material perforado y acústico. Con el mismo material se pueden forrar los frontales y traseras de los armarios de puertas correderas.



Gli screen dividers sono disponibili in materiali diversi: in melaminico, in laccato opaco, in metacrilato oppure in materiale 'tackable' fonoassorbente. Lo stesso materiale può essere utilizzato per il rivestimento di fronti e schiene dei contenitori in melaminico con ante scorrevoli modulari.



Atreo has a new and functional side storage cabinet equipped with an integral pedestal and CPU holder. The cabinet provides storage and supports the desk. The cushion placed over the pedestal allows the user (or guest) to use the cabinet as a seat.

Les plans de travail avec angles arrondis, disponibles en version simple ou double en vis à vis, pouvant se poser aussi sur les rangements latéraux avec blocs tiroirs et niche UC intégrés, offrent de nouvelles réponses esthétiques et fonctionnelles. Le coussin placé sur le bloc tiroirs permet une assise d'appoint pour l'utilisateur ou le visiteur

Las superficies o encimeras con esquinas redondeadas, sencillas o dobles, apoyadas en muebles auxiliares con cajonera y porta CPU integrado, ofrecen soluciones estéticas y funcionales originales. El cojín opcional transforma la cajonera en una sillita informal.



I piani scrivania con angoli arrotondati, singoli o doppi, sovrapposti a contenitori laterali con cassettiere e porta CPU integrati, offrono nuove soluzioni estetiche e funzionali. Il cuscino sovrapposto alla cassettiere consente all'operatore (o al visitatore) di utilizzare il contenitore come seduta.



The ATREO wave tops allow you to create different table configurations with multifunctional use. With the several finishes available for tops and legs, multiple colour combinations can be arranged.

Les plans courbe d'Atreo permettent la conception de tables multi fonctionnelles curvilignes. De nombreuses options de finitions couleur existent tant pour les plans que pour les pieds.

Con las superficies curvas de ATREO se pueden realizar mesas multifuncionales. La gran variedad de acabados para las estructuras y superficies permiten múltiples combinaciones de colores.



Con i piani curvati di ATREO si possono realizzare tavoli polifunzionali curvilinei. Le numerose opzioni di finitura per piani e gambe consentono molteplici combinazioni di colore.



Pensati per biblioteche e sale lettura, i tavoli ATREO di forma sagomata abbinati a screen in metacrilato curvati (a seguire il design del piano) conferiscono all'ambiente freschezza e creatività.

Designed initially for libraries and reading rooms, ATREO wave tables and screens deliver freshness and creativity to the site.

Conçus pour les bibliothèques et les salles de lecture, les tables Atreo de forme courbe associés aux écrans de séparation en méthacrylate (suivant la forme du plateau) apportent fraîcheur et créativité à l'ambiance.

Diseñadas para bibliotecas y salas de lectura, las mesas ATREO de formas curvas combinadas con las mamparas en acrílico del mismo diseño brindan frescura y creatividad.





ATREO





P551911 Gamba a cavalletto / A-shape leg / Piètement trèteau / Pata de caballete

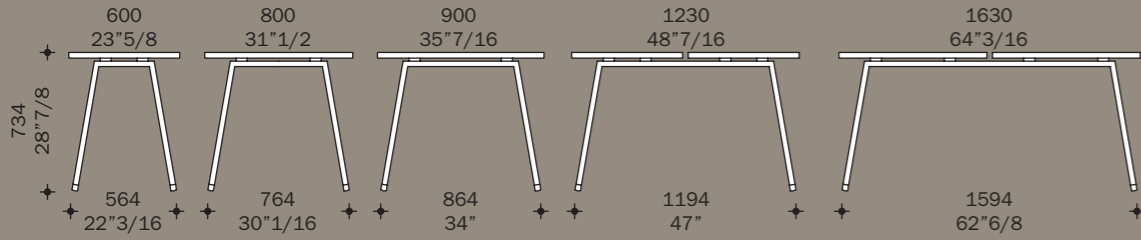

P551913

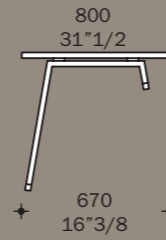

P551914

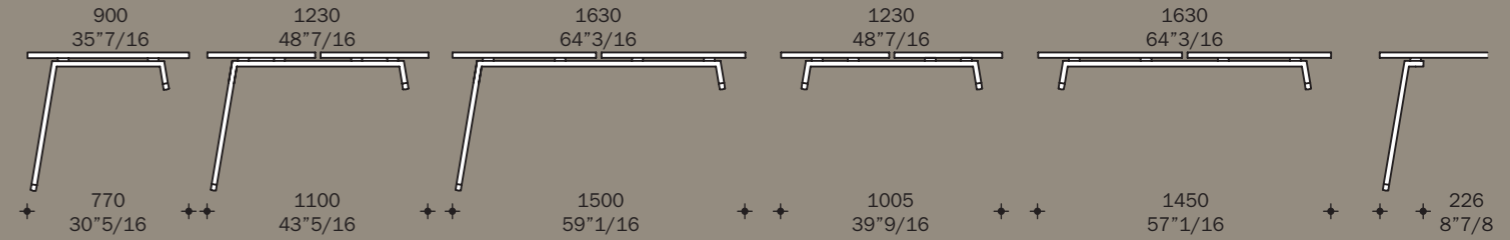

P5519P11

P551912 Gamba a cavalletto regolabile / Adjustable A-shape leg / Piètement trèteau réglable en ht. / Pata de caballete regulable en altura

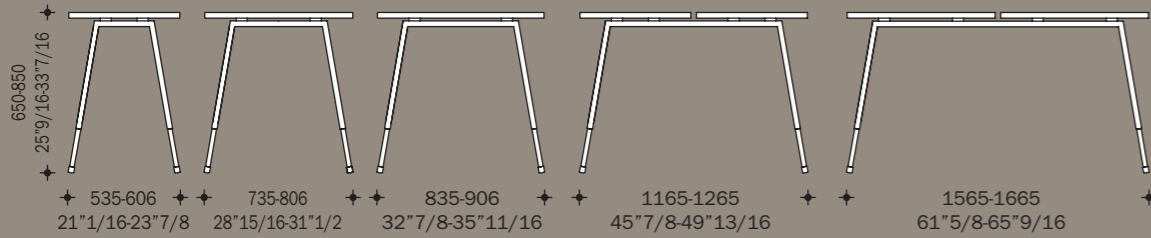

P551921 Gamba a ponte / Straight leg / Piètement droit / Pata recta

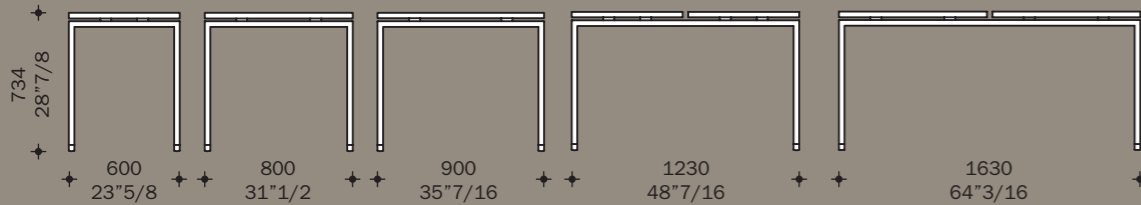

P551923

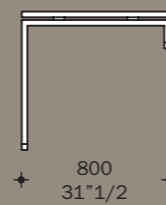

P551924

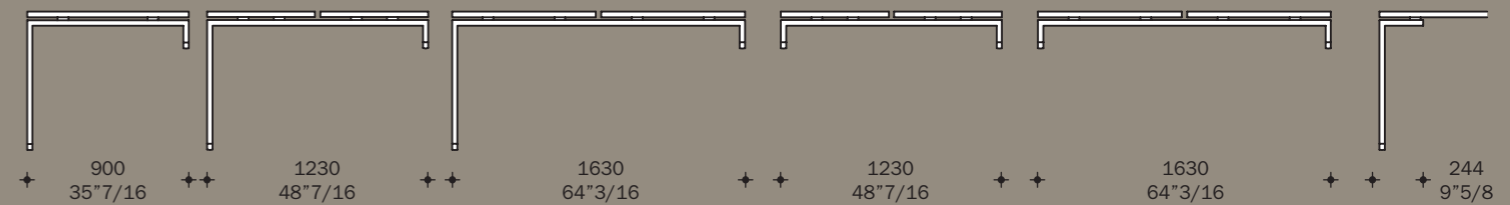

P5519P21

P551921 Gamba a ponte / Straight leg / Piètement droit / Pata recta

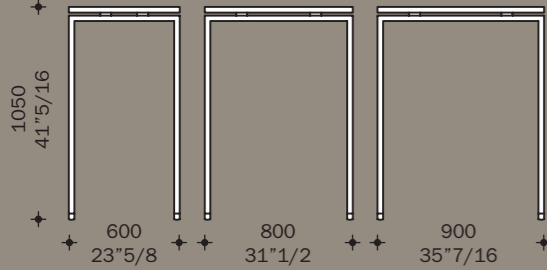

P551921 Gamba a ponte regolabile / Adjustable straight leg / Piètement droit réglable en ht. / Pata recta regulable en altura

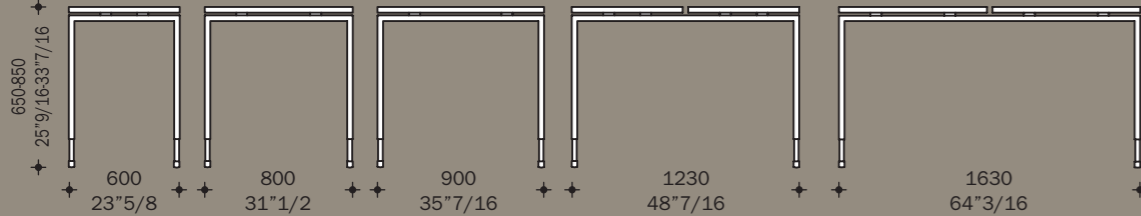

P551821

Gamba a ponte tavolino caffè / Coffee table straight leg
Pied droit petite table à café / Pata recta mesa para café

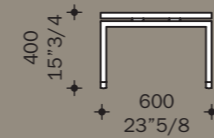

P5518A1

Gamba ad anello tavolino caffè / Coffee table closed loop leg
Pied fermè petite table à café / Pata anillo mesa para café

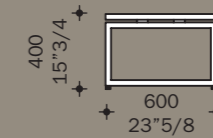

Basamento / Base for bench solution / Base de support bench / Columna central para bench

P5519A1 Gamba ad anello / Closed loop leg / Pied fermè / Pata anillo

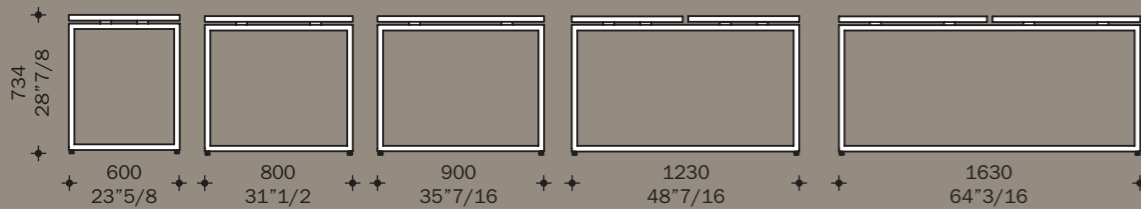

P5519A2 Gamba ad anello regolabile / Adjustable closed loop leg / Pied fermè réglable en ht. / Pata anillo regulable en altura

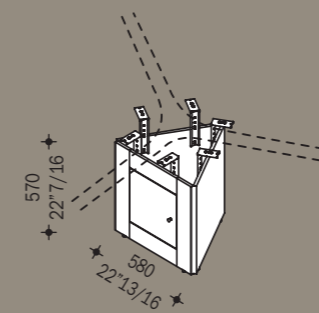
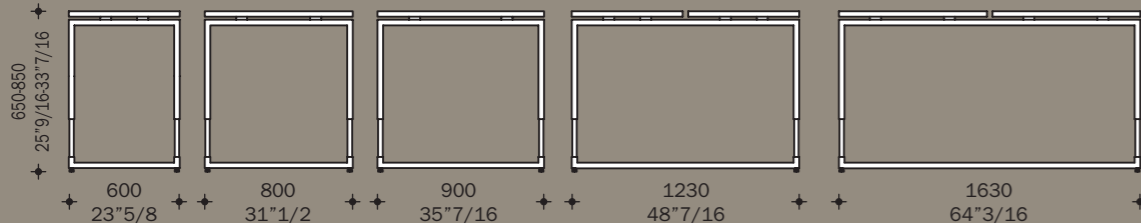



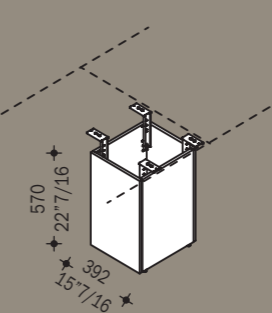



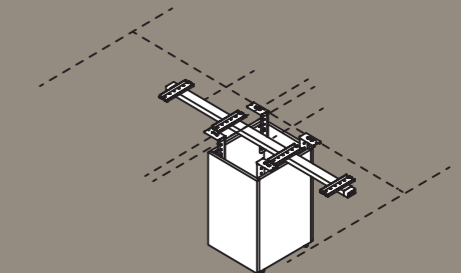





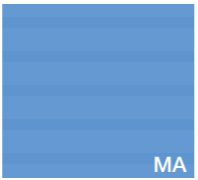

P5519T
Basamento triangolare 120°
Base for cluster solution 120°
Base triangulaire 120°
Columna central para banch 120°

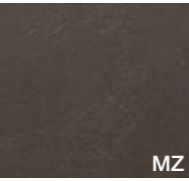

P5519M
Basamento bench singolo
Bases for bench solution
Base de support
Columna central para banch sencillo

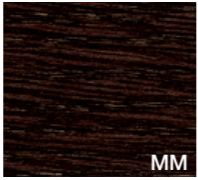

P5519MT
Basamento bench doppio
Bases for bench solution
Base de support
Columna central para banch doble





 Bianco rigato <i>Rippled effect white</i> Blanc avec rayures en sérigraphie Blanco rayado	 Grigio rigato <i>Rippled effect grey</i> Gris avec rayures en sérigraphie Gris rayado	 Arancione rigato <i>Rippled effect orange</i> Orange avec rayures en sérigraphie Naranja rayado	 Azzurro rigato <i>Rippled effect blue</i> Bleu avec rayures en sérigraphie Azul rayado	 Verde rigato <i>Rippled effect green</i> Vert avec rayures en sérigraphie Verde rayado	
 Bianco <i>White</i> Blanc Blanco	 Talco <i>Talco</i> Talco Talco	 Ardesia <i>Ardesia</i> Ardesia Pizarra	 Noisette <i>Noisette</i> Talco Noisette	 Nichel <i>Nickel</i> Nickel Niquel	 Cacao <i>Cocoa</i> Cacao Cacao
 Rovere chiaro <i>Light oak</i> Chêne clair Roble claro	 Rovere americano <i>American oak</i> Chêne américain Roble americano	 Rovere grigio <i>Grey oak</i> Chêne gris Roble gris	 Rovere moro <i>Dark oak</i> Chêne foncé Roble oscuro	 Noce Chiaro <i>Walnut</i> Noyer Nogal	 Noce Canaletto <i>Canaletto Walnut</i> Noyer Canaletto Nogal Canaletto
Piano <i>Top</i> Plateau Sobre	Modesty panel <i>Modesty panel</i> Voile de fond Faldón	Screen <i>Screen</i> Écran Panel	Contenitori strutturali <i>Structural storage</i> Meuble retour fixe Armarios estructurales	Corpetti <i>Overhead</i> Rangements Contenedores	Console <i>Console</i> Console Consola

Tessuto *Fabric Tissu Tejido*

 Crema <i>Crema</i> Crème Crema	 Tortora <i>Turtledove</i> Tourterelle Tortola	 Grigio <i>Grey</i> Gris Gris	 Arancione <i>Orange</i> Orange Naranja	 Rosso <i>Red</i> Rouge Rojo	 Blu <i>Blue</i> Bleu Azul
 Blu avio <i>Sky blue</i> Bleu clair Azul "Avio"	 Verde acqua <i>Aqua green</i> Vert d'eau Verde agua				
Screen <i>Screen</i> Écran Panel	Cuscino <i>Cushion</i> Coussin Cojín				

• Le finiture contenute nel presente catalogo sono puramente indicative e non sono di riferimento per le forniture del prodotto.
• Due to the printing process, finishes shown in this catalogue are for illustration only. The finish on the final item may differ slightly from the printed illustration.

Goffrato *Embossed Gaufré Matt lackiert Gofrado*

 Goffrato Moka <i>Embossed Mocha</i> Gaufré Moka Gofrado Café	 Goffrato Indaco <i>Embossed Indigo</i> Gaufré Indigo Gofrado Azul Indigo	 Goffrato Rubino <i>Embossed Ruby</i> Gaufré Rubis Gofrado Rubi	 Goffrato Cedro <i>Embossed lime green</i> Gaufré vert Cédrot Gofrado verde Cedro	 Goffrato Argento <i>Embossed Silver</i> Gaufré Argent Gofrado Plata	 Goffrato bianco <i>Embossed white</i> Gaufré blanc Gofrado blanco
 Goffrato nero <i>Embossed black</i> Gaufré noir Lacado negro	 Goffrato rosso "F" <i>Embossed red "F"</i> Gaufré rouge "F" Lacado rojo "F"	 Goffrato arancione <i>Embossed orange</i> Gaufré indigo Lacado naranja	 Goffrato grigio scuro <i>Embossed grey</i> Gaufré gris Lacado gris	 Goffrato azzurro <i>Embossed blue</i> Gaufré bleu Lacado azul	 Goffrato verde <i>Embossed green</i> Gaufré vert Lacado verde
 Ardesia <i>Ardesia</i> Ardesia Pizarra	 Noisette <i>Noisette</i> Noisette Noisette				
Screen <i>Screen</i> Écran Panel					

• Les finitions contenues dans ce catalogue ne sont pas contractuelles - les photos ne pouvant rendre la parfaite réalité.
• Die Farbwiedergabe dieses Katalogs kann aus drucktechnischen Gründen von den fertigen Produkten abweichen. Ebenso sind technische und konstruktive Änderungen zur Modell-Optimierung möglich.
• Los acabados contenidos en este catálogo son puramente indicativos y no son de referencia para los suministros del producto.

Metacrilato Metacrylate Méthacrylate Acrylglas Metacrilato



Trasparente
Transparent
Transparent
Transparente

Rosso trasparente
Red transparent
Rouge transparent
Rojo transparente

Blu trasparente
Blue transparent
Bleu transparent
Azul transparente

Bianco satinato
Satin-finish white
Blanc satiné
Blanco satinado

Arancione satinato
Satin-finish orange
Orange satiné
Naranja satinado

Blu satinato
Satin-finish blue
Bleu satiné
Azul satinado

Verde satinato
Satin-finish green
Vert satiné
Verde satinado

Grigio fumè satinato
Satin-finish smoky grey
Gris satiné
Gris satinado

Bianco opalino
Opaline white
Blanc opalin
Blanco opaco

Screen
Screen
Écran
Panel

Corpetti (ante)
Overhead (doors)
Rangements (portes)
Contenedores (puertas)

Epossidico Epoxy Epoxyde Einbrennlackiert Epoxidico



Bianco
White
Blanc
Blanco

Grigio
Grey
Gris
Gris

Noisette
Noisette
Noisette
Noisette

Ardesia
Ardesia
Ardesia
Pizarra

Verde
Green
Vert
Verde

Arancione
Orange
Orange
Naranja

Azzurro
Blue
Bleu
Azul

Bronzo
Bronze
Bronze
Bronce

Sabbia
Cream
Sable
Arena

Nero
Black
Noir
Negro

Talco
Talco
Talco
Talco

Gamba
Leg
Pied
Pata

design
Filippon

art direction
Mirto Antonel

AB/CABH/AB

- Le finiture contenute nel presente catalogo sono puramente indicative e non sono di riferimento per le forniture del prodotto.
- Due to the printing process, finishes shown in this catalogue are for illustration only. The finish on the final item may differ slightly from the printed illustration.
- Les finitions contenues dans ce catalogue ne sont pas contractuelles - les photos ne pouvant rendre la parfaite réalité.
- Die Farbwiedergabe dieses Katalogs kann aus drucktechnischen Gründen von den fertigen Produkten abweichen. Ebenso sind technische und konstruktive Änderungen zur Modell-Optimierung möglich.
- Los acabados contenidos en este catálogo son puramente indicativos y no son de referencia para los suministros del producto.